



# **South Tynedale Railway**

# **RULE BOOK**

**JANUARY 2024**

# RULE BOOK

## Preface

The South Tynedale Railway operates an integrated Safety Management System (SMS) to manage safety on the Railway and to ensure that it operates its trains in a safe manner. This Rule Book is a requirement of and part of the South Tynedale Railway SMS.

This Rule Book was approved by the Board of Trustees on xx.yy.2024 to supersede all previous issues of the Railway's Rules and comes into operation from xx.yy.2024.

By Order of the Board of Trustees>

**NAME: David Granath**



## Document History

Current Issue: **January 2024**

Amendment List

Date	Amended by	Amendment
May 2008	MR GD Rail	Full Review
Jan 2009	STRPS N H Cook	Revised Section H –T to members
Apr 2010	STRPS N H Cook	General Revision and formatting
Feb 2011	STRPS N H Cook	Complete Re-issue
July 2011	STRPS N H Cook	Revised Section H (Brake Test) to members
Mar 2012	STRPS N H Cook	Revised Section K and added Section L other minor revisions to Section G, S and T.
Apr 2012	STRPS D J Potter	Rule L1e revised
Mar 2015	Rule Book committee	Full Review & update
Dec.2020	STRPS P Austen	Full Review and Update
Apr 2021	STRPS K Malone	Revisions after Martyn Ashworth's ICP feedback
May 2021	STRPS K Malone	May 2021 Version Effective 10.05.21.
Jan 2024	STRPS K Malone	Jan 24 - Page numbers added to contents listing on Page 3. Minor text revisions to Sections B+C Sec B (Personal track safety) Page 11 Sec C (Introduction) top of Page 15 Spelling and punctuation revised, bold text for emphasis added, where necessary.

## CONTENTS.

## PAGE NUMBERS

Section A. General rules for everyone.	5-10
Section B. Personal Track safety.	11-14
Section C. Fixed signals.	15-23
Section D. Degraded working – failure of signalling equipment.	24-26
Section E. The Duty Operations Manager	27-28
Section F. Special working during extreme weather conditions.	29
Section G. One train working – operation of the single line.	30-31
Section H. Working of trains.	32-41
Section I. Continuous automatic air brake.	42-46
Section J. Shunting.	47-50
Section K. Train detained at a signal.	51
Section L. Not used.	52
Section M. Accidents, obstructions and failed trains.	53-56
Section N. Locomotives and rolling stock.	57
Section O. Not used.	58
Section P. Not used.	58
Section Q. Not used.	58
Section R. Not used.	58
Section S. Not used.	58
Section T. Possessions and work on or near the line.	59-61

Section U. Not used.	62
Section V. Not used.	62
Section W. Workshop and running sheds.	63
Section X. Not used.	64
Section Y. Communications.	65
Section Z. Not used.	66
Appendix One – Definitions and Abbreviations.	67-69
Appendix Two – Definitions and Duties.	70
Appendix Three – Diagram Map of the Line.	71-77

**THIS IS THE RULE BOOK OF THE  
SOUTH TYNEDALE RAILWAY PRESERVATION SOCIETY**

**SECTION A - GENERAL RULES FOR EVERYONE.**

**All STRPS Staff & Volunteers are required to be familiar with this Part of the Rule Book.**

**A1 Compliance.**

A1.a The South Tynedale Railway Preservation Society (hereafter referred to as the STRPS) has stated its intention to comply with the authority under which it has permission to operate and with all current legislation and regulations, which apply to it as a heritage light railway. Accordingly, the Railway operates a Safety Management System (SMS) of which this Rule Book is a part.

A1.b Individual compliance by all STRPS staff & volunteers with the Rule Book is a condition of being permitted to work anywhere on the railway.

## **A2 Health and Safety.**

A2.a Any railway, regardless of gauge, is a potentially hazardous place. Safety first must be everyone's primary concern, i.e. the safety of yourself, your colleagues, the passengers, trains, equipment and the Infrastructure of the STRPS. It is essential for all STRPS staff & volunteers and our passengers that the railway is operated in a safe and professional manner.

A2.b The Health and Safety Policy of the STRPS is defined in the railway's SMS System.

A2.c All STRPS Staff & volunteers are reminded that they are responsible for their own safety and for the effect that their behaviour may have on colleagues or the general public. All STRPS staff & volunteers while on STRPS property will adhere to the site behaviours which are posted for information at various internal locations.

A2.d In the terms of the Health and Safety at Work Act 1974 (and associated Acts), the Board of Trustees should be considered as the Employer and any other STRPS staff & volunteers as Employees (although in the case of volunteers that term carries no legal relevance other than for H&S). The attention of STRPS staff & volunteers is drawn to the statutory notices supplied by the Health and Safety Executive, and to other notices relating to safe working practices, as displayed in the General Office and Heritage Engineering Workshop.

## **A3 Signing on for Duty.**

A3.a All STRPS operating staff & volunteers must sign in as they report for duty and must sign out as they leave the site at the end of their duties.

Signing-on for duty at the railway confirms that they are:

- & Signing on at the correct time, fit for duty, they have had 12 hours rest since their last safety critical duty.
- Are free from the influence of alcohol or drugs which could impair their performance.

Before commencing duty, all staff and volunteers must, in addition to the above:

- Read, all relevant operating and special notices posted at the signing on point.

A3.b STRPS staff & volunteers on duty must report for duty in good time to ensure that the first train of the day departs on schedule.

The duty DOM for a passenger service operating day, should be on duty at least one and a half hours before the departure of the first service train of the day.

Train crews should report in good time to prepare the locomotive for service, to bring the locomotive into the station, attach to the train and complete all necessary tests prior to the departure of the first service train. Additional time must be allowed for if the locomotive(s) require taking on fuel and/or water prior to attaching to the train.

Guards must report for duty in time to collect any equipment from the mess room and carry out a Fitness to Run inspection of the coaching stock to be used before the locomotive is attached.

Signalmen must report for duty in time to open the Alston signal box and prepare the route for locomotives coming off shed into the station.

Slaggyford Crossing Keepers must report direct to Slaggyford at least half an hour (30 minutes) before the first train departure from Alston and report by radio or telephone to the Alston signalman, who must record that Slaggyford signal box is manned in the Train Recording Book.

A3.c Any person unable to report for duty must inform the Railway as early as possible and at least one hour before their rostered start time, or if possible, the day before they are rostered. The DOM must be informed of any rostered operational role not covered and attempt to find replacement(s).

## **A4 Public Access to Restricted Areas.**

- A4.a Restricted areas are those not generally open to the general public.
- A4.b Access is usually permissible, subject to the permission of the DOM and being accompanied by STRPS staff or volunteer who are qualified to be in that location.  
Visitors permitted to access Restricted Areas must be issued with suitable high visibility clothing and, if required, other PPE. Permission will be refused if it compromises their safety or the safety of others.
- A4.c A person, other than Train Crew or other STRPS staff or volunteer, may be allowed to ride on a locomotive footplate, provided that authority is given by the DOM and an indemnity has been signed. No more than 3 (THREE) persons including the train crew may occupy a locomotive footplate.
- A4.d If STRPS staff or volunteer see anyone in a restricted area apparently unsupervised, they should be asked, politely, if they have permission to be there, and if so, from whom. They should then be escorted either to the person who gave the authority or from the premises if that person is not available.

#### **A5 Issue of Rule Books and Associated Instructions.**

- A5.a This Rule Book is issued to all STRPS staff and volunteers at the start of their training, either electronically or as a printed copy, no later than the end of the first day of duties.
- A5.b Members of the STRPS not meeting the definition of 'volunteer' are treated as the general public.
- A5.c Paper copies of this Rule Book in ring binders are available for consultation by on-duty STRPS staff & volunteers at the following locations at the STRPS: - In the mess room, in both Signal Boxes, in all Guards vans, on all operational locomotive footplates and the DOMs Office.  
STRPS staff & volunteers will be issued with a memory stick with an electronic copy of the authorised version of the Rule Book. As an alternative, a CD or printed copy will be made available, if necessary.
- A5.d STRPS staff & volunteers will be required to provide a record of their receipt of an authorised copy of the Rule Book, and any additional instructions either by a paper or electronic signature and that they agree to comply with the requirements of the of the of the Rule Book. This rule also applies to any future amendments to the Rule Book.
- A5.e STRPS staff & volunteers are responsible for keeping up-to-date, and properly amended, their personal copy of the Rule Book and any additional instructions, either by printed or electronic media. This responsibility also applies to any amendments to the Rule Book that may be published in the future.
- A5.f When amendments to the Rule Book are issued, STRPS staff & volunteers will be notified of the change via the regular means of communication and the Mess Room Notice Board. They are responsible for ensuring that they have obtained and familiarised themselves with any amendment to the Rules or other instructions prior to their next taking duty. A signed receipt form must be returned and recorded in the Register kept by the Railway.
- A5.g From time to time, Special instructions will be issued for major events or other occasions when additional or varied instructions are required. Details of these will be shown on the 'Signing-On' sheet and at the locations specified above in Section A3. All event STRPS staff & volunteers are required to ensure that they have a copy of any such instructions relevant to their competencies or allocated duty, on the date(s) on which such Special instructions will apply.

#### **A6 STRPS Staff & Volunteers and their Interactions with Members of the Public.**

- A6.a STRPS staff & volunteers who have direct contact with members of the public should always be smartly dressed. They should always be courteous to members of the public, who provide the income that allows the STRPS to operate. Remaining courteous can sometimes be difficult and where a member or members of the public become abusive, they should be referred to the DOM.  
STRPS staff & volunteers must be seen to be working safely and professionally at all times.

## **A7 Mandatory Levels of Qualification to Perform Duties.**

- A7.a Where a specific role (e.g. Guard) is referred to in the Rule Book, or in any associated instructions, it means that ONLY a person qualified in that role must perform the duty. 'Qualified' means having been examined in the Rules and Regulations of the STRPS and been passed as competent in that role by an STRPS or external examiner. Trainees may undertake a task or duties as part of their learning but only under the direct supervision of a person qualified to undertake that task or duty. In such circumstances, the qualified duty holder is responsible for the task being carried out correctly.
- A7.b Training in the mandatory basic grades of 'Railwayman 1' and 'Railwayman 2' is available to all prospective STRPS staff & volunteers (subject to any medical limitations).
- A7.c A 'Railwayman 1' and 'Railwayman 2' must be aged 18 years or over on qualification. Qualification as 'Railwayman 2' is mandatory before commencing training for any other operating duty.
- A7.d Only STRPS staff & volunteers holding a 'Railwayman 1' qualification are permitted to be on or near the line or to work on the lineside, or to be anywhere other than in areas which are open to the public: this includes walking to or from any place of work.
- A7.e Only STRPS staff & volunteers who are qualified as 'Railwayman 2' are authorised to carry out shunting duties, couple/uncouple vehicles, apply/release vehicle brakes, operate ground frames and hand points, and give signals to indicate a requirement to move non-passenger-carrying vehicles/trains.
- A7.f Only STRPS staff & volunteers who are qualified as a Guard are permitted to take control of the movement of vehicles/trains carrying members of the public.
- A7.g Only STRPS staff & volunteers who are qualified as a Signaller are permitted to operate a signal box (except where specific authority to the contrary is given in this Rule Book and for those operations permitted under Railwayman 2 qualifications).
- A7.h Only STRPS staff & volunteers qualified as a Crossing Keeper may only operate the signal box and crossing gates at Slaggyford.
- A7.i Only STRPS staff & volunteers who are qualified as Signal Technicians may disconnect or reconnect or alter any mechanical or electrical signalling equipment, pointwork operating equipment or interlocking. If signalling fails during operations, in order to keep trains running, provisions for temporary arrangements are set out below in C4 (flag and lamp signals by the Signaller) and C24 (Provision of a Hand signaller)
- A7.j Only STRPS staff & volunteers who are qualified as Drivers, Firemen and Secondman by the STRPS may perform the duties of these roles.
- A7.k Persons qualified on any other railway to a particular level of competency must not be allowed to carry out any unsupervised work on the STRPS at that level until they have been STRPS staff & volunteers qualified in the STRPS Rule Book or other instructions. If such persons have to be supervised, the STRPS staff & volunteers supervising them must be qualified in the duties concerned.

## **A8 Personal Safety.**

- A8.a STRPS staff & volunteers carrying out duties or walking on any part of the railway track, must wear suitable high-visibility clothing and safety footwear where Risk Assessments require the wearing of specific PPE.
- A8.b STRPS staff & volunteers who engage with the public should be neatly dressed, and where engaged solely on platform duties must have suitable high-visibility clothing to hand.
- A8.c STRPS staff & volunteers working with any kind of machinery or coupling, or uncoupling vehicles or handling loads must ensure that they do not wear any loose items of clothing; long hair must be suitably restrained.
- A8.d STRPS staff & volunteers must ensure that they are familiar with and use the safest route of access to their place of work.
- A8.e STRPS staff & volunteers must not walk on or near the line when a path away from the railway is available and may only walk on or near the line when their duties require them to be there.
- A8.f STRPS staff & volunteers must only carry out tasks which they are competent to perform and which they are authorised by the railway to perform.

- A8.g STRPS staff & volunteers must not carry out a task which they feel is unsafe, they must not put themselves in a position of danger and they must endeavour to prevent a dangerous occurrence from taking place. All dangerous occurrences or near misses must be reported to the Duty Operations Manager (DOM) and recorded for analysis by the railway in order to learn lessons for the future.
- A8.h Operational procedures must be carried out in accordance with the requirements of the Rule Book and any supplements or other instructions issued by the STRPS management.
- A8.i STRPS staff & volunteers must only use plant, tools, or equipment, on which they have been trained and authorised to use.
- A8.j STRPS staff & volunteers must only use plant, tools, or equipment for the task or work they are designed to perform and in accordance with the instructions for their correct use.
- A8.k Any defective plant, tools, or equipment must be disabled and labelled, in accordance with safety policy to indicate that it must not be used. Any defect, particularly one affecting the safety and operation of the Railway, must be reported immediately to the DOM and noted in the Log Book. Where possible, an STRPSPS Trustee concerned should also be informed.
- A8.l All STRPS staff & volunteers must familiarise themselves with the Railway's Health and Safety and Accident Reporting Procedures. (SMS Section 11).
- A8.m Any matters of concern in respect of Health and Safety, working practices or equipment must be reported immediately to the senior member of the department concerned who is on duty. A written report must be submitted by the complainant prior to leaving the Railway's premises.
- A8.n STRPS staff & volunteers must not board or dismount from a moving train or light engine.

#### **A9 Internal Radio System.**

- A9.a The STRPS operates an internal radio communication system using a combination of fixed and hand- held transceivers. The system is used for all communications between Alston and Slaggyford and may be used to summon assistance or give notice that a relief locomotive should be prepared to assist a failed train.
- A9.b In addition to fixed radios (e.g. Guards vans and signal boxes) ALL STRPS staff & volunteers on operational duty must be issued with a fully charged portable radio at the start of their duty, which must be checked for correct operation between all intended operational contacts at the start of their duty.
- A9.c All Drivers, Guards, Signalmen, Shunters, the DOM and STRPS staff & volunteers working on the line north of Alston Shed must carry a portable radio, which must be returned to the DOM's office at the end of duties.

#### **A10 External Telephone Contact.**

- A10.a 01434 382070 is an external line, as the contact number for users of accommodation level crossings for railway operating purposes, when vehicles, long loads or animals are intended to be taken across the line. A telephone to answer calls on this number is located in Alston Signal Box.
- A10.b When the Railway is operating this number must only be answered in the Alston Signal Box by the Alston Signalmen. In the event that someone other than the Signalmen (e.g. a Trainee Signalmen) answers a call, the Signalmen must be contacted immediately and asked to speak to the caller.

#### **A11 Reporting of Personal Accidents.**

- A11.a Any personal accidents, however minor, must be reported immediately to the DOM and must be entered in the Accident Book. The DOM must record details in their Logbook and arrange First Aid attendance or, if necessary, call an ambulance.
- A11.b The DOM must ensure, as far as is possible, that full name, address, and any other relevant details in respect of the injured person, are recorded at the time of the incident (including witnesses).

## **A12 Reporting of Defects, Incidents and Unusual Circumstances.**

- A12.a Any unusual circumstances, e.g. trespassers, cattle etc. on the line, or anything otherwise potentially affecting the safe operation of trains, must be immediately reported to the Signaller who must arrange for trains to be stopped, advise the DOM, and record the details in the Train Register Book. The DOM must immediately arrange for the matter to be investigated and the line to be cleared. Full details must be recorded in the DOM's Logbook.
- A12.b STRPSPS Trustees must regularly check and initial the DOM's Logbook for any reported defects etc. which may have occurred since they were last on site and try to ensure that a repair is affected.
- A12.c STRPSPS Trustees must also ensure that any defects etc. reported through the DOM's Log Book are noted in that book as 'repaired' once the defect has been dealt with.

## **A13 Single Manning of Diesel Locomotives.**

- A13.a Diesel locomotives fitted with an operational DSD can be single manned. Diesel locomotives without an operational DSD should, be double manned. In the event of a driver being taken ill the second man must assume control of the locomotive and train.

## **A14 Minimum Ages for Staff and Volunteers .**

- A1.14a. There are specific minimum ages for all operational staff and volunteers at the STRPS.

These are as follows:

Driver - steam, diesel, battery electric - 21

Fireman - 18

Diesel Second Man - 18

Guard - 18

Shunter – 18

Signaller - 21

DOM – 21

## **SECTION B - PERSONAL TRACK SAFETY.**

**All STR staff & volunteers must be qualified in Section B, prior to carrying out any work, including walking on or near the line and working in the workshop and shed areas.**

**In addition, please read section J pages 47 – 50 which concern personal safety during shunting, particularly, in relation to going between rail vehicles and going between rail vehicles and stop blocks.**

The purpose of this section is to ensure the personal safety of all STR staff & volunteers whose work on the Railway takes them on to or near the line, also to assist in ensuring the safety of others working or travelling on the Railway.

Safety of yourself and all others on the railway, staff and passengers, is the highest priority. Personal track safety training is essential for all STR staff & volunteers whose duties necessitate them being "on or near the line" as defined in Rule B1.b below. This includes any contractors engaged to work "on or near the line".

### **B1 Basic Terminology.**

- B1.a The area between the running rails is known as the 'two foot'.
- B1.b The area between the outer rail edge and the lineside boundary, when no other line intervenes, is known as "the cess". The cess must always be regarded as being included in the term 'on or near the line'.
- B1.c A 'position of safety' means a distance greater than 2 metres (6ft 6ins) from the nearest rail edge.  
If more than one person wishes to use the same position of safety, there must be sufficient space to safely accommodate both/all of them at a greater distance than 2 metres from the nearest rail.
- B1.d Where any two lines are adjacent to each other a position of safety requires a minimum distance of 2 metres from both lines, plus space in which to stand clear of that distance – from both lines.
- B1.e The term 'train' or 'train movement' means anything, including a light locomotive or item of rolling stock which is moving or can move on any part of the Railway including sidings.
- B1.f The term 'high visibility clothing' or 'HVC' means garments or over garments which have been approved by the Railway for the purpose of making the wearer more visible or distinguishable. These must be orange in colour with reflective strips.
- B1.g The term 'personal protective equipment' or 'PPE' means items which offer the wearer some protection or reduction of potential injury, etc. when carrying out certain tasks.
- B1.h The terms 'hand tools' or 'light tools' when used describe those tools which are used manually by a single person and include such items as forks, shovels, pick-axes, crowbars and jacks as well as smaller tools such as hammers, spanners, and screwdrivers. Small power tools such as electric drills, grinders, etc. are also considered 'hand-tools'.

Power tools such as strimmers, hedge trimmers, and Kango type hammers are not 'hand-tools'.

## B2 A Position of Safety.

- B2a This diagram shows in simple form the meaning of 'a position of safety' in which STRPS staff & volunteers and any equipment they are carrying can position themselves a minimum of **2 METRES (6 feet 6 inches)** from the nearest rail edge.

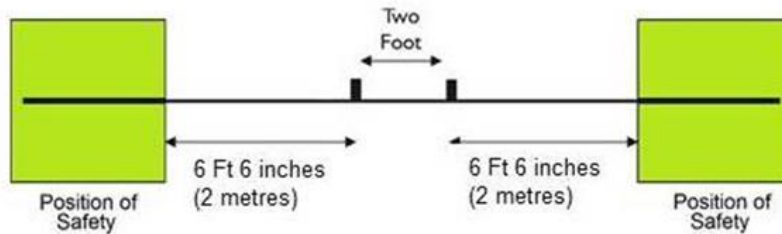

- B2b The area labelled 'two foot' indicates the position of a track and in this case only a single line of track is shown.
- B2c Where there is more than one line of track, e.g. in a station area or sidings, there might not be a position of safety between them.
- B2d STRPS staff & volunteers must take special care at all times in such areas to know where the nearest position of safety is and the safest way of reaching it.

## B3 Working or Walking on or near the Line.

A railway is a place where there are trip hazards, large and hazardous items of machinery can move very quietly. Trains, even small trains, cannot stop quickly and they are a lot more solid than you!

- B3.a You must only go on or near the line if your duties take you there.
- B3.b When on or near the line, you must wear high visibility clothing and safety footwear during normal operations. Locomotive Drivers and Firemen are exempt from the high visibility clothing requirement except when on the running line for purposes such as coupling and uncoupling. Guards and Signalmen must wear high visibility clothing when their duties require them to be on or near the line, such as when performing shunting, coupling and uncoupling, performing brake tests, inspecting the track and signalling equipment.
- B3.c You are always responsible for your own safety; you must be aware of and understand all Rules and instructions relating to the work you are doing.
- B3.d You must never walk in the 'two foot' except to cross the line or when the requirements of your work mean you have to be there. When walking on or near the line always walk on the ballast never walk on the sleepers or point timbers. Wooden track materials can be very slippery when wet, even when the surface looks safe, retained moisture can mean the surface is still a significant hazard.
- B3.e The South Tyne Trail footpath beside the line, is generally the best route for walking along the railway and a safer walking surface, without the trip hazards of the railway track.
- B3.f You must always walk as far from the nearest rail edge as you safely can and you must keep a careful eye out where you are walking and on the underfoot conditions.
- B3.g On a single line railway you cannot always walk to face oncoming rail traffic, so you must watch and listen at all times for a train movement from the opposite direction or an approaching train from behind.
- B3.h If you hear an engine whistle or horn, it may be a warning to you, look at the approaching locomotive. Remember, if the train is being shunted, it may be being propelled with the locomotive at the rear and the movement will be under the control of the shunter who may be walking beside or on the leading vehicle). You must follow this procedure:

- Get to the nearest position of safety.
- Raise one hand above your head to acknowledge the warning and wait for the driver to acknowledge by whistle or horn that they have seen you.
- Remain in the place of safety until the whole of the train has gone past you.
- Before moving away from the place of safety, make sure there is no approaching train from another direction.

B3.i You must take extra care if you are walking on the line with others - your attention must be on your personal safety, not on conversation.

B3.j You must not walk on sleepers as they can become very slippery in all sorts of weather conditions.

B3.k Never run, you are less likely to concentrate on where you are going if you are running.

#### **B4 Crossing Lines or Sidings.**

When you cross a line, even a siding, you expose yourself to greater danger, because this is where there are trains, unexpected movements and often very poor sighting.

B4.a Never assume that people such as locomotive Drivers or Shunters can see you; their primary job is the movement they are making - not looking for you!

Never assume that people such as locomotive Drivers or Shunters can see you, while they are keeping a sharp lookout on the line they are also busy and may not see you or you may be obscured by vehicles or other objects.

B4.b If there is a made up (to rail level) foot crossing available, use it carefully, especially in wet or icy conditions.

B4.c Always pick a safe place to cross – this is one where it is easy to reach a position of safety, because there are a minimum number of lines and where there are fewer hazards and the best view in all directions from which a train might approach. Always cross the line at 90 degrees stepping only on the ballast. Never cross the line at points.

B4.d Before you cross: STOP, LOOK, and LISTEN. Remain observant, as you cross. On single line railways like the STRPS, be aware that trains can come from either direction.

B4.e Cross all the way, do not stop. Complete your crossing of the rails by walking to the next position of safety.

B4.f Do not cross if there are any train movements at all in the vicinity, even if you think they do not affect you. Only cross if you are absolutely sure that a train movement cannot take place on get onto the line(s) you are going to cross.

B4.g If a signal is at danger it does not mean that a train will not come along, but if a signal is off it probably does mean that there will be a train coming soon.

B4.h If you have to step over rails take great care to avoid tripping. Take care also to avoid tripping on signal wires and point rodding.

#### **B5 Working or Walking in Yards or near Sidings.**

Yards and sidings present greater hazards because stabled vehicles can obstruct sight lines and it can also be more difficult to get to a position of safety.

B5.a In yards or around sidings always use the route which enables you to get to the nearest position of safety. Plan where this is in advance.

B5.b Do not walk between sidings when you can walk outside the siding area.

- B5.c Do not cross any line or siding within 20 feet of a standing vehicle; unless you know it is not going to move/be moved.
- B5.d Do not cross any line or siding between a vehicle and the siding stop blocks (buffer stops). Go round the end of the siding.

### **B6 Walking where work is taking place on Locomotives.**

All locomotives pose numerous hazards to the unwary.

- B6.a Keep clear of any area where any work is being carried out on a locomotive. There is a risk of injury, eg from escaping steam or hot water. Among numerous other hazards, there is a chance that a locomotive may move without warning.

### **B7 Using hand or light tools on the line.**

- B7.a When you are using hand tools or light tools on the line you must move them with you to a position of safety when a train approaches and until it has passed your work site. You must ensure that all such equipment is kept a minimum of 2m (6ft 6ins) from the nearest running rail.

### **B8 Working or Walking on the Line in Difficult Locations.**

You might think you are safely out of the way of the railway but do not forget that what you do could affect the safety of the railway, and yourself.

- B8.a If you are working in a cutting or anywhere where the ground slopes down towards the railway, take great care to secure tools and materials, including rubbish, to stop it and most importantly yourself falling towards the line. Embankments can be similarly hazardous as there is a risk of falling down the embankment in trying to reach a Place of Safety.
- B8.b Overhead power lines can be a hazard; make sure you know where they are and that they will not be affected by your work and your safety will not be at risk.
- B8.c Before commencing work (especially excavation), ascertain whether there are any hidden services which could be affected (in particular the Gas Main which runs alongside the whole railway).

### **B9 Authority to work on the Line or Lineside.**

- B9.a You can only carry out work on the line or at the lineside when you have the correct authority and permission to do so.
- B9.b Section T contains the Rules which cover the various types of possession (a way of protecting the work and the safety of trains). You may only carry out work on the line or lineside in accordance with the procedures in that Section.
- B9.c The protection of STRPS staff & volunteers carrying out other work, e.g. working on rolling stock or unloading rail vehicles in a siding should be carried out as given in T.30. You may only carry out work on vehicles, etc. in accordance with the procedures in that Section.

## SECTION C – FIXED SIGNALS.

**The purpose of this section is to explain the principles and practices that control the operation of the railway’s signalling system.**



The four main purposes of a signalling system are: -

1. Everyone involved with the operation of trains has a common understanding of the appearance and meaning of fixed or hand signals and lineside signs used on the Railway
2. To control the passage of trains.
3. To prevent conflicting movements.
- 4 To give drivers an indication of the state of the line ahead.

STR staff & volunteers involved in operating trains must understand the signalling system including all fixed and hand signals. STR staff & volunteers who have access to the line must also understand the meaning of signals.

**Any person noticing the failure of any Fixed Signal or Absence of any lineside signs must report this at the earliest opportunity to the DOM.** In such circumstances the DOM must ensure that Drivers are advised and post a suitable notice on the Signing-On Noticeboard and also record details in his or her Logbook.

### C1 Fixed Signals - Stop Signals.

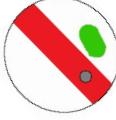
Description	Signal ON	Signal OFF
STOP Signal	 Red – STOP	 Green – Proceed
Shunting Signal	 Red – STOP	 Green – Proceed

- C1.a Stop signals controlling running movements (known as Running Signals) comprise a red semaphore arm with a square end and a vertical white stripe.
- C1.b Stop signals controlling shunting movements comprise either a red semaphore arm with a square end and a vertical white stripe or a white disc with a horizontal red band.
- C1.c At the divergence of one route from another, the route is indicated by:
- i) A separate arm mounted on a separate doll on a bracket structure. The arm furthest to the left reads to the route furthest to the left and each successive arm to the right of that reads to the next line to the right. The elevation of the semaphore arms indicates the relative importance of the routes.
  - ii) Vertical stacking of arms, where the top-most arm indicates the route furthest to the left and each successive arm below that reads to the next line to the right. There is no indication of the relative importance of the routes.

### C1 Fixed Signals - Stop Signals.

C1.d The meaning of stop signals is as follows:-

DESCRIPTION OF SIGNAL INDICATION Type of Movement	Indication by day	Indication by night	Meaning
DANGER (ON)	Semaphore arm horizontal Or white disc with the red band horizontal	A red light	<b>STOP</b>
PROCEED (OFF)  Running Movement	Semaphore arm raised 45°.	A green light	When controlling a running movement, this indication means PROCEED as far as the next stop signal or buffer stop. See also Rule C.3a
PROCEED (OFF) Shunting Movement from running signal.	Semaphore arm raised 45°.	A green light	When controlling a shunting movement this indication means <u>proceed with caution</u> only as far as the line is clear, keeping a sharp lookout for hand signals and obstructions. See also Rule C.3a
PROCEED (OFF) Shunting Movement from disc signal.	White disc with the red band rotated 45° from the horizontal.	A green light	Proceed with caution only as far as the line is clear.

## C2 Fixed Signals - Distant Signals.

C2.a Distant Signals comprise a yellow arm with a fishtail end and black chevron.

(All distant signals on the STRPS are fixed at caution)

Distant(Caution) Signal	 <p>Yellow – Prepare to Stop at next signal</p>	(All distant signals on the STRPS are fixed at Caution.)
-------------------------	--	--

C.2b The meaning of distant signals is as follows:

DESCRIPTION OF SIGNAL INDICATION Type of Movement	Indication by day	Indication by night	Meaning
CAUTION	Arm horizontal	A yellow light	Be prepared to STOP at the next stop signal or other specified place to which the distant signal applies.

### **C3 Shunting Movements from Running Signals.**

Subsidiary signals are not used on this Railway.

C3.a A running signal may be used to signal a shunting movement provided that the Signalman has first ensured that the vehicles or any other obstruction towards which the movement will be made will not be moved.

C3.b The Signalman must ensure that the locomotive making the shunting movement is brought to a stand at the signal. The Signalman must then ensure that the Driver understands that the movement is towards an occupied line and is required to stop short of any obstruction or hand danger signal on that line.

C3.c Provided the Signalman has complied with Rules C3a and b the signal for the shunting movement may be cleared.

C3.d Shunting towards loaded passenger trains is not permitted except in order to attach the locomotive(s) which will work the train. An additional empty coach may be added to/detached from a loaded passenger train provided that the loaded coaches are not moved.

Shunting of loaded passenger trains is only permissible in an emergency.

### **C4 Passing Signals at Danger.**

C4.a When it is necessary for a signal which cannot be cleared for any reason to be passed at danger the Signalman must first ensure that the route is correctly set and properly secured for the safe passage of the train.



C4.b The Signalman must then ensure that the Driver understands why the signal is to be passed at danger and what movement is to take place.

C4.c When this has been done the Signalman must exhibit a green hand signal to the Driver as authority to pass the signal at danger.

C4.d The Driver must sound the locomotive whistle/horn to acknowledge the hand signal and sound a long whistle as he goes past the fixed signal at danger and thereafter proceed with caution.

C4.e When the Section Signal is to be passed at Danger, the provisions of Rules C4a to C4.f apply.

### **C5 Stop Board.**

STOP Board	 STOP – then follow inSTRPSuctions	InSTRPSuctions may vary and the board may be accompanied by a red light
RED Lamp	STOP 	Used on Buffer Stops and Level Crossing Gates

C5.a STOP boards display a solid red circle with the word 'STOP' beneath it. The board may be reflectorised and may also display additional inSTRPSuctions. The board has the same meaning as a signal at danger and if it is passed without proper authority the incident will be treated as a signal passed at danger (Section C4).



The Driver, or person controlling a movement, must bring the train to a stand at the STOP board and may proceed only in accordance with the InSTRPSuctions displayed on the board, or as otherwise authorised.

C5.b Provision may be made for covering some STOP boards which under certain operating conditions do not apply. Details are provided in the Sectional Appendix, where applicable

### C6 Lighting of Signal Lamps.

C6.a Stop signal lamps must be lit when train operations take place during the hours of darkness, or if visibility is reduced because of bad weather. On the STRPS, signal lamps are normally illuminated when trains are operating.

### C7 One Train Working Section Marker Boards.

START	 Proceed only when in possession of Staff, Ticket or Token for the Section.	May also be White on Red
END		May also be Black on White with Red border

The limits of a One Train Working (OTW) section are denoted by marker boards.





C7.a The markers are either White rectangular boards with a Red border, or Red rectangular boards with white lettering, worded 'Start of One Train Working' on the side visible to trains approaching the OTW Section and 'End of One Train Working' on the side visible to trains leaving the OTW Section.

C7.b These boards are reminders of the Instructions contained in Section G and no movement is permitted to pass the board worded 'Start of One Train Working' except as in Section G.

**C8 Signals Not In Use.**

C8.a Signals and STOP and other such boards which are not in use will have a large white 'X' on the face of the signal or will be covered over.

**C9 – C12: Other Lineside Signs in Use on the STRPS.**

<p>User Worked Level Crossings</p>		
<p>Footpath Crossing</p>		
<p>Platform Sign No Trespassing</p>		
<p>Limited Clearance</p>		

**C9 Whistle Boards.**

WHISTLE	 <p>Driver to sound General Warning on the whistle or horn</p>	
---------	---	--

- C9.a Whistle Boards comprise a circular sign with a white background bordered by a red circle. The centre of the sign displays a large black 'W'.
- C9.b Whistle boards are provided where there are user-worked level crossings and at other locations with hazards due to restricted approach sighting.
- C9.c On passing a Whistle Board, the Driver must sound a 'general warning' and keep a sharp lookout until the hazard has been passed.
- C9.d Extra vigilance is required when a propelling move is required to pass a Whistle Board. The warning should be given as the leading vehicle passes the Whistle board.

**C10 Lineside Signing of Restrictions of Speed.**

Signs Indicating Permanent Speed Restrictions (PSRs)

PERMANENT SPEED RESTRPSICTION		<p>A yellow arrow may be added below the number to indicate speed applied to diverging route.</p> <p>The back of the sign indicates the end of the restriction.</p>
-------------------------------	---	---

- C10.a Lineside signs are shown as a yellow cut-out numeral, the number indicates the maximum speed in mph. permitted from that point. Where the numeral is accompanied by an arrow (pointing either to the left or the right) it indicates that the speed applies to the line diverging in that direction and not to the main route ahead.
- C10.b A PSR terminates on passing the rear of the sign indicating the start for the opposite direction. The rear of the sign is black. Normal line speed must not be resumed until the rearmost vehicle of the train has passed this board.

**C11 Signs Indicating Temporary Speed restrictions (TSRs)**

C11.a WARNING BOARDS are sited 100 yards to the rear of the point at which the temporary restriction commences and indicate the maximum speed permitted. Speed is shown in white on a black background above an arrow coloured yellow.



C11.b COMMENCEMENT BOARD – Sited at the commencement of the restriction, the number indicates the maximum speed in mph. permitted from that point. Black number on a white background.



C11.c TERMINATION BOARD – Sited at the terminating point of the restriction. Normal line speed must not be resumed until the rearmost vehicle of the train has passed this board.

White letter 'T' on a black background.



If they are sited to the right of the main line but on the left of any adjacent line they must be arrowed to indicate the line to which they apply.

**C12 NOT TO BE MOVED Boards**

NOT TO BE MOVED		The vehicle or locomotive to which this sign is fixed must NOT be moved except with the express permission of the person so fixing it.
-----------------	--	--

C12.a White rectangle with red border and the words "NOT TO BE MOVED"

C12.b Not to be moved boards are placed on a vehicle when work is taking place on or below the vehicle.

C12.c Only the person who placed the board on a vehicle may remove it. Except in the case of a Not to be Moved board fixed for the purpose of battery charging which must be moved by the next operative on duty before the vehicle is moved.

C12.d Not train movement may take place less than 6 feet from a vehicle on which a "Not to be Moved" board has been placed. Buffering up to a vehicle with a "Not to be Moved" board is strictly prohibited.

**C13 to C21 Hand and Whistle Signals.**

**C13 STOP:**

- a) A red flag, target, or lamp.
- b) Both arms raised above the head.
- c) When riding on or in a vehicle – either shoulder level.
- d) (at night) any light waved vigorously.



arm held out steadily at

**C14 Caution or Slow Down:**

- a) Either arm moved slowly up and down to shoulder level.
- b) (at night) A green light (See C.16 or C.17).



**C15 All Right:**

- a) Either arm held above the head.



**C16 Move Away From Handsignal:**

- a) Either arm moved in a circular manner away from the
- b) White Lamp waved slowly up and down.
- c) Green Lamp waved slowly up and down = move slowly.



body.

**C17 Move towards Handsignal:**

- a) Either arm moved across and towards the body at shoulder
- b) White Lamp waved slowly from side to side.
- c) Green Lamp waved slowly from side to side = move slowly.



level.

**C18 Create Brake Pipe Pressure:**

- a) Arm moved vertically up and down above shoulder.
- b) Red Lamp moved vertically up and down above shoulder.



**C19 Apply Brake and DeSTRPSoy Air in Train Pipe:**

- a) Move flat hand back and forth across throat
- b) Red Lamp moved from side to side across chest



**C20 Close up loco to another vehicle:**

- a) Indicates to the driver the distance between the loco and another vehicle or loco to which the loco is be coupled by holding both arms apart to one side of the body and gradually closing them as the distance is reduced.
- c) This hand signal MUST NOT be given with arms above the head to avoid confusion with C13 STOP.
- d) When contact between the couplings is made use hand signal C13 STOP.



### **C21 Guard's Signal to the Driver that a Train is Ready to Start:**

C21.a A green hand signal held steadily or waved above the head, accompanied by a 'double blast' whistle signal.

### **C22 Platform Staff's Signal to the Guard that Duties are complete, etc.**

C22.a This signifies that all carriage doors are shut and no more persons intend to join or alight from the train before departure.

C22.b Platform Staff must face the Guard and raise their arm on the side nearest to the train in the 'All Right' hand signal (C15).

C22.c At night or in poor visibility, exhibit a white light. NO other person other than the Guard may exhibit a Green signal.

### **C23 Signals during Shunting.**

C23.a The standard STOP, Move Towards, Move Away, Slow Down and Close Up hand and/or lamp signals are used. (C13, C14, C16, C17 and C20).

C23.b If the Driver loses sight of the Shunter he must STOP immediately until one of sight is restored. In an emergency, a signal of ONE LONG WHISTLE BLAST may be given by the shunter. In order to avoid potential misunderstanding, this is the ONLY audible signal authorised for use by during shunting.

C23.c The use of radio or similar method of communication during shunting must be in accordance with the requirements of Section Y.

### **C24 Duties of a Hand signalman on duty at a Fixed Signal.**

C24.a If necessary, a Hand signal man may be appointed to assist the Signalman in the event of signal failure(s) or disconnection(s). The hand signalman must work in accordance with the instructions given by the Signalman. The Hand signalman must be equipped with a Red Flag and a Green Flag and a hand lamp able to display Red and Green.

C24.b When on duty at stop signals the Hand signalman must display a red hand signal to any approaching train movement.

C24.c Hand signalman only shows a YELLOW flag to proceed, not green. This is because if there is a signalling failure, the security of the route is not proved by the interlocking but done visually by drivers and signalman, so only a yellow for proceed at caution.

C24.d The DOM must advise train crews when hand signalling is in operation and when it is withdrawn.

## **SECTION D – DEGRADED WORKING.**

### **Failed Signalling Equipment/Loss of a single line token/Automatic brake failure on a train.**

The purpose of this section is to ensure that where normal train operating procedures cannot be carried out, such the failure of the signalling equipment (e.g. through the snapping of a signal wire), loss or damage of the single line token or failure of the continuous automatic brake in ONE vehicle, there are established procedures to be followed to restore either normal methods of working or alternative temporary methods to ensure the safe operation of the railway.

### **D1 Failure of Signalling Equipment.**

- D1.a In normal operation, the signalling systems including the operation of ground frames are protected by interlocking. Points over which passenger trains operate are protected by facing point locks (FPL) to prevent inadvertent movement of the point blades. This section includes alternative emergency provisions should any equipment fail.
- D1.b It must be stressed that any alteration, repair, disconnecting or reconnecting of signalling equipment may ONLY be carried out by a qualified Signal & Telegraph (S&T) Technician. Any unauthorised person found carrying out alteration of signalling equipment will be instantly suspended from duty by the DOM and disciplinary procedures may be taken against that person.
- D1.c Any failure of the signalling equipment must be recorded in the signal box where the failure occurs. The failure must also be reported to the DOM at once, who will record it in the DOM log and, if an S&T Technician is not on duty, agree with the Signaller what alternative procedures may be put in place to allow the safe continued working of trains.
- D1.d Semaphore signals are designed in the event of failure to drop to the horizontal STOP position. Usually a broken signal wire causes this. If a signal cannot be pulled off to the PROCEED aspect, the DOM may appoint a hand signaller to work under the Signaller's direction to enable the continued safe working of trains.
- D1.e If a FPL cannot be locked to protect a point over which passenger trains run, the point must be secured in the correct position by means of a padlocked point clamp. The key must be attached to the single line token. If the point is normally used for locomotives to run round their train, the DOM may consider operating trains in "Top and Tail" formation.
- D1.f If an S&T Technician is on duty, such emergency work to restore normal working of the equipment controlled by the signal boxes at Alston or Slaggyford must be agreed with the DOM and Signaller. The work must be carried out under a Between Trains Possession (T.3). The S&T Technician must agree with the Signaller what work is to be done and the order in which it is to be done. Collars must be placed on any levers which are affected by the work. The Signaller must record details of what is to be disconnected, and the entry must be checked and counter-signed by the S&T Technician.
- D1.g Before the Signaller permits any movement to take place, he/she must ascertain from the S&T Technician that it is safe to operate the levers etc. concerned, and that the S&T Technician and any other persons will be in a place of safety.
- D1.h On completion of the work, the Signaller and the S&T Technician must test all equipment which has been disconnected or affected by the disconnections. If the results are satisfactory, the Signaller must again make an entry in the TRB which the S&T Technician must counter-sign. The S&T Technician must inform the DOM of the satisfactory completion of the work who must record this in the DOM's log.
- D1.i If the work cannot be completed on the day on which it was started, the Signaller must, before going off duty, record all disconnected or disarranged items in the TRB and inform the DOM of all disconnected or disarranged items. The work to complete restoration of the equipment to its normal state must be continued on a day when the operation of trains is not set to occur under an Absolute Possession (Section D2).
- D1.j If the Token is required by the S&T Technician while work is taking place, the S&T Technician must retain possession of the token and obtain an absolute possession, and the operation of trains must be suspended by the DOM.
- D1.k If there is no Signaller on duty when the work is carried out, the S&T Technician must be responsible for entering details in the TRB and for ensuring that everything is thoroughly tested before signing off the work as "complete".
- D1.l Any planned work to maintain signalling equipment which could affect normal operations must be carried out under an absolute possession on days when normal train services are not operating. Details of how the S&T Technician is to carry out work and prove it are contained in SMS.

## **D2 Loss of or damage to the Single Line Token and Working by Pilotman.**

- D2.a In normal working on the single line a train is protected by the Driver having possession of the token or ticket. If the token is lost and a thorough search fails to find it, working by Pilotman must be carried out. The Pilotman is in effect a human token to ensure that only one train occupies the single line OTW at any one time.

- D2.b If the token is damaged it may continue in use provided that the name of the OTW Section remains clearly legible. If the name of the OTW Section is not legible, working by Pilotman must be introduced.
- D2.c If the token is lost or damaged such that it may not be used, the DOM must appoint a Pilotman and ensure that train crew are advised that Working by Pilotman is being introduced.
- D2.d The Pilotman must sign on duty in the Train Register Book (TRB) and must then put on his/her left sleeve the red armband bearing the title 'Pilotman'. If the token is damaged but still available, the Pilotman must take possession of it until such time as relief is arranged or Working by Pilotman is withdrawn.
- D.2e The Pilotman must, in lieu of the token, accompany all trains entering the OTW section and must, on the authority of the Signaller instruct Drivers to pass at danger the section signal (where provided) .
- D.2f If it is necessary to change over Pilotmen, this must only be done at the location where the current Pilotman took on the duty. The Pilotman being relieved must handover the armband to his or her replacement and both must sign the entry in the Train Register.
- D2.g Working by Pilotman must continue until either the token is replaced or operations cease for the day. If a replacement token has not been provided prior to the next operating day then Working by Pilotman must again be introduced.
- D2.h It is not permitted for the Driver of a passenger train to act as the Pilotman while in charge of his or her train. However, exceptionally and in order to avoid delay, the Driver of a works train may act as the Pilotman for his or her own train provided that passenger trains are not operating, and will not be operating, on that day.
- D2.i The Pilotman must, if a train is worked by more than one locomotive, ride on the rearmost working locomotive.
- D2.j When a lost or damaged token is replaced by a new token the changeover must take place at Alston Signal box. If working by Pilotman is in operation the Pilotman must be present in the signal box when the new token is made available and Working by Pilotman must be immediately withdrawn.
- D2.k The Signaller must, when a damaged token is withdrawn from use, immediately hand that token to the DOM and a suitable entry must be made in the Train Register Book and countersigned by the DOM.
  
- D2.l The DOM is responsible for ensuring that the withdrawn token is safely secured out of use pending handing over to S&T team.  
If the damaged token has been in use for longer than one operating day the DOM must also post a notice advising train crews that the Token has been replaced.
- D2.m When damage to the token prevents it from releasing the intermediate ground frames, or when the Token is lost and Working by Pilotman is in operation, all trains within the OTW Section must be operated with a locomotive at each end (top and tail working).
- D2.n Alternatively, provided resources are available, the arrangements shown in Rules S.40 to S.44 may be introduced.

### **D3 Failure of the Automatic Brake in a Passenger Train.**

- D3.a In the event of an equipment failure of the continuous automatic brake (eg the brakes on one vehicle fail to release), it is possible to isolate and release the continuous brake on an individual vehicle. It must be clearly understood that when a brake is isolated in this manner it will no longer operate on that vehicle which becomes a piped vehicle and will cease to provide any braking force in the train. Drivers must adjust the speed of the train accordingly. A passenger train may, if necessary, as a result of defect occurring in service, continue for one journey only with the continuous brake isolated on ONE passenger-carrying vehicle provided that the continuous brake is fully operational on all 4 axles of the **rearmost** passenger-carrying vehicle. Passengers should be requested to move from a coach where the brakes have been isolated to another coach.

D3.b If a fault occurs on a train en-route the continuous brake must be isolated on the vehicle concerned and that vehicle may be taken as far as necessary as a piped vehicle.

D3.c In order to isolate the brake on a vehicle the following procedure must be carried out:

- The vehicle's isolating cock must be closed to isolate the vehicle's brake system from the train pipe.
- The vehicle's reservoir drain cock must be opened until all air has exhausted from the reservoir; the drain cock must then be closed.
- If the vehicle is to be moved a visual check must be made to ensure that the automatic airbrake has fully released, D3a.-b. above, the defective vehicle is the rearmost passenger-carrying vehicle the passengers must be moved forward to the other passenger-carrying vehicles at the first available opportunity.

## **SECTION E – THE DUTY OPERATIONS MANAGER.**

**The purpose of this section is to emphasise the Rule Book requirements in respect of the Duty Operations Manager's role and responsibilities. Other requirements and responsibilities of the post are detailed in a separate procedural document issued to Duty Operations Managers.**

### **E1 Role and Responsibility.**

- E1.a A Duty Operations Manager (DOM) must be appointed and on duty on the Railway on all occasions when any passenger train movement is being made or is to be made.
- E1.b During the time on duty the DOM is the 'responsible person' in charge of the Railway's operations and the management and monitoring of operational standards.
- E1.c The DOM has the authority to suspend from duty any person seen to be unfit for duty or who fails to comply with the requirements of the Rule Book or any additional, special or other reasonable operational Instructions.
- E1.d The DOM is responsible, on taking duty, for ensuring that all operational STRPS staff & volunteers roster requirements for that day have been met and, if this is not the case, for endeavouring to arrange cover for any uncovered duties. At the end of the day, the DOM must ensure that all STRPS staff & volunteers on duty have signed off and are accounted for.

### **E2 Monitoring and Reporting.**

- E2.a The DOM has an important mandatory role in fulfilling the initial stages in the statutory monitoring of standards (e.g. STRPS staff & volunteers fitness for duty) and in the recording and reporting of incidents and matters relating to the fitness of the Railway to operate trains.
- E2.b The DOM on duty is responsible for maintaining and updating information to STRPS staff & volunteers and management shown on the Signing-On Noticeboard and as otherwise specified by the Rule Book or any additional Instruction.

### **E3 Maintaining the Log Book.**

- E3.a The DOM must maintain a Log Book which must, as a minimum, record: -
  - The reported problems, with the Railway's infrastructure at the time duty commences and finishes.
  - All reportable events and incidents.
  - Any other out-of-course (i.e. unplanned or unintended) events or incidents of which the DOM has been informed that have occurred during their turn of duty; any incident of STRPS staff or volunteer indiscipline such as failure to comply with requirements.
  - Any event which this Rule Book or any other InSTRPSuction requires to be recorded in the Log Book.
- E3.b The Log Book must be written and maintained in a clear and concise manner and must be kept available when not in use.
- E3.c The DOM must summarise at the end of the turn of duty note of any items which have been reported as defective or not available for normal operation or carried over from the previous entry unless it has been reported, and recorded currently, that the item has been dealt with or rectified.

### **E4 Maintaining Information on Notice Boards.**

- E4.a The DOM is required by a number of items in the Rule Book to ensure that information is drawn to the attention of STRPS staff & volunteers by posting details on the Signing-On Notice board.
- E4.b Additionally before leaving duty the DOM must ensure that any information recorded in the Log Book which is also required to be shown on the Signing-On Notice board is actually shown on that Noticeboard.

- E4.c On taking up duty the DOM must review the infrastructure information recorded at the end of the previous DOM's turn of duty and ensure that all relevant items are posted on notices at the Signing-On Noticeboard.

### **E5 Undertaking Other Duties.**

- E5.a When passenger trains are operating, or are intended to operate; during their turn of duty the DOM must not undertake any other duties other than Alston Signaller unless there is no alternative. The DOM must carry a portable radio, thus maintaining a communication link.

## **SECTION F – SPECIAL WORKING DURING EXTREME WEATHER CONDITIONS.**

- F.a In extreme weather conditions it will be necessary to put extra precautions in place and to employ greater vigilance to ensure the STRPS continues to operate safely. If the DOM is in any doubt that trains can be operated safely they must suspend services.
- F.b In all cases where visibility is reduced due to extreme weather conditions e.g., falling snow, fog etc, drivers must reduce speed and proceed at caution. The locomotive whistle or horn should be used more and especially at places where the driver is in doubt whether persons on or about the line would be aware of his approach.
- F.c In the case of thick fog - if visibility falls to less than 200 yards trains must proceed at caution only. That is, at a maximum speed of 5 mph over the entire STRPS.  
Trains **MUST** stop at signals, whistling before proceeding if signals are cleared.  
At level crossings, if no gate man is provided, the fireman should go ahead on foot and signal to the driver that it is safe to proceed using a hand lamp.
- F.d In the case of falling snow – rules F1.b & F1.c above must be complied with.  
In addition - snow can affect the working of signals - in extreme situations it might be necessary to place a hand signaller at the signal and exhibit a red light to bring trains to a stand. The driver must stop then whistle and proceed when the signal is cleared and the Hand Signaller shows a green light signal.
- F.e In these conditions the permanent way will need to be checked and the points will need to be cleared if they have become blocked with snow and ice.
- F.f In the case of heavy rainfall - flooding becomes a risk and it may be necessary for the entire railway to be examined before passenger trains can be operated. It might be necessary to run a non-passenger train first to ensure that all is well and also to impose speed restrictions on some or all of the railway for a time.
- F.g If flood waters are above track level passenger trains must be suspended. Where trains are moving through flooding steam locomotives must go at walking pace and must make sure that the ash pan is above water level.  
Diesel mechanical or diesel hydraulic locomotives can proceed at walking pace but battery electric locomotives must not be used, started or moved, in these conditions.
- F.h Where locomotives and rolling stock have been used in such conditions they must not be used again until they have had a full FTR examination and been declared fit to run again.
- F.i In the case of high winds - all STRPS staff must be vigilant for objects being blown across the running lines e.g. trees, telegraph poles etc. Any obstruction should be reported immediately to the DOM. If signalling equipment becomes unstable the DOM and the signaller should be advised immediately.

## **SECTION G – ONE TRAIN WORKING (OTW) RULES FOR THE OPERATION OF THE SINGLE LINE**

'One Train Working' means that only one train, locomotive or self-propelled on-track machine is allowed to occupy the single line section at any one time. The purpose of this section of the rule book is to ensure the OTW method of operation authorized for the single line between Alston and Slaggyford is correctly and safely applied.

The single line between Alston and Slaggyford is under the control of the signaller at Alston and no train is permitted to enter the single line section without their permission. A token, coloured red and marked Alston-Slaggyford, is used in conjunction with the signalling system to ensure the integrity of the OTW principle between these two stations.

All traincrew, signallers, persons undertaking shunting work and persons taking possession of the single line section are required to be qualified in the knowledge of this regulation.

### **Limits of the OTW Section.**

The OTW section extends from and back to the *Start of one train working-End of one train working* marker board in advance of the section signal (no. 14) at Alston and is under the control of the signaller at Alston.

The OTW section includes the run-round loops at Kirkhaugh and Slaggyford and extends to final terminating point of the line at Slaggyford. It does not include the dock sidings at Kirkhaugh and Slaggyford which may be used to shut in vehicles clear of the OTW section in accordance with local instructions (see regulation G1.l below).

### **G1 Regulations.**

- G1.a Drivers must ensure that before their train enters the OTW section they are in possession of the token (except as shown in Section M).
- G1.b When the token is handed to the driver in the pouch they must, before entering the OTW section, check that the correct token is in the pouch.
- G1.c When a train is worked by more than one locomotive the token must be shown to each driver and be handed to the driver of the rearmost locomotive.
- G1.d Drivers must, before entering the OTW section from Alston, additionally ensure that the section signal (No. A14) has been cleared for their train.
- G1.e After a train has entered the OTW section it must not be divided but must continue, complete in the formation in which it entered the section, until it reaches the point at which it exits the section (except as shown in Section M).
- G1.f The driver may, on arrival at Kirkhaugh, surrender the token to a shunter, or guard acting in the role of shunter, for the sole purpose of releasing the ground frame.
- G1.g While the token is in the possession of a shunter at Kirkhaugh, the shunter is responsible for the safety of all movements and must instruct drivers accordingly. If no shunter is available at Kirkhaugh, the driver will be responsible for all movements of their locomotive and for carrying out the instructions of section G1.f
- G1.h The guard of a train departing from any intermediate location in the direction of Alston (up trains) must advise the Alston signaller of their intention to depart. The guard must speak personally to the signaller. It is not permissible to pass a message via a third party.
- G1.i When advised that a train is departing for Alston, the Alston signaller must ensure that the line is clear to the platform line stop block at Alston and the route correctly set for that train. No other routes may be set when an up-passenger train is in section until that train has arrived in the platform at Alston, (except as shown in Section M).
- G1.j The driver must retain possession of the token until the whole of the train has passed the *end of one train working* board at Alston. The token must then be surrendered to the signaller who must satisfy him or herself that the train is complete through observation of the tail lamp.

- G1.k No shunting movement may pass *the start of one train working* board whilst the OTW section is occupied.
- G1.l Any vehicles that are detached for any reason to be stabled in the dock sidings at Kirkhaugh or Slaggyford must be shunted clear of the OTW section and secured. The OTW section must then be protected by means of the trap points in accordance with the local Instructions for those locations.

06/21

## SECTION H – WORKING OF TRAINS.

The purpose of this section is to ensure that the Railway operates its trains in a safe manner and that the STRPS staff & volunteers involved in train operations are aware of their duties. Some aspects of train operating are dealt with in other sections and those sections must be read in conjunction with this Section.

This section sets out the basic criteria for train operation, the types of trains and how they must be formed or equipped, and the general duties of STRPS staff & volunteers involved in the operation of trains. Further Rules and duties are included in the sections relating to specific locations and regulations; operating STRPS staff & volunteers are also required to be qualified in these further Rules and regulations as appropriate to the duties they are performing on the Railway.

This Section is sub-divided as follows: -

Rules prefixed 'H' apply to all classes of train (unless shown otherwise).

Rules prefixed 'HA' apply additionally to passenger trains.

Rules prefixed 'HF' apply additionally to Freight Trains and light locomotives.

### H1 Types of Train.

The Railway operates the following classes of train: –

H1.a Passenger Train: Any train, which carries any persons who are not STRPS staff & volunteers, is classified as a passenger train.

H1.b Freight Train: A train conveying freight vehicles for demonstration purposes or the movement of materials loaded fully within loading gauge where stopping within Section is not intended.

For the purposes of these Rules a light locomotive, or locomotives coupled together, is classified as a Freight Train.

H1.c Works Train (also known as an 'Engineering Train'). A train conveying vehicles and/or materials and tools to be used in connection with any sort of infrastructure engineering work which will involve the train stopping in-Section to load, unload or perform any other duties. A manually propelled trolley is classified as a Works Train.

Note: Works Trains are only permitted to operate in a Possession and, as such, are dealt with in Section T.

### H2 Maximum Permitted Speeds.

H2.a The maximum permitted speed of trains on the Railway is 15 mph and is subject to lower limits as shown in Rules H2.b-e below. Where a lower limit is indicated, this applies until the whole of the train has passed through the limited length.

H2.b Speed is permanently restricted to 5 mph at the following locations: –

- In all sidings where, in addition, speed must be limited to enable stopping short of any obstruction or other movement (driving "on sight")
- Through points which have a diverging route
- Within the limits of Alston, Kirkhaugh and Slaggyford stations
- The section of the line at the Water Board Crossing and the Holms footpath crossing
- At such other locations which are indicated by yellow cut-out numerals at the lineside as explained in Rule C10.
- When a train is being propelled on any part of the railway.

H2.c Speed is permanently restricted to 2mph when entering sheds or workshops.

H2.d Temporary restrictions of speed are indicated by lineside signs which are explained in Rule C11.

The absence of such signs does not relieve Drivers of the responsibility to observe temporary restrictions of speed, the details of which have been posted on the Signing-On Notice board

- H2.e Any train not fitted with continuous brakes must not exceed a speed that will enable the Driver to safely stop the train, under all circumstances, with the locomotive brakes alone. The Driver must take account of the make-up of the train (weight and type of vehicles) together with the prevailing gradients, track conditions and weather conditions.
- H2.f In the case of a locomotive fitted with only a handbrake, no train should exceed 5 mph, and the Driver must observe the conditions of Rule H.2e above with great care. During normal operations, only in exceptional circumstances, and with written authority of the DOM, they may be used in the OTW Section, and the Driver and Guard must exercise extreme care in handling the train.
- H2.g At user-worked level crossings which are provided with Whistle Boards, drivers must after giving the 'general warning' signal, control the train speed approaching the level crossing to enable the train to stop if there is any obstruction.

### **H3 Head and Tail Lamps.**

- H3.a All trains must carry a white headlamp at the front and a red tail lamp at the rear. If a locomotive is fitted with electric head and tail lights these may be used.
- H3.b In conditions of poor visibility (e.g. heavy rain or fog) and after dark these lamps must be lit, exhibiting a white light to the front and a red light to the rear.
- H3.c The Driver is responsible for ensuring the headlamp is present.
- H3.d The red tail lamp can be used as protection of the train prior to a locomotive being coupled to it (e.g. if someone is between or under a coach(es) to carry out maintenance). Drivers must stop at least 6ft (2 m) short if the tail lamp is in place. Only the Guard may remove the tail lamp. The Guard must remove the tail lamp before calling on the locomotive.
- H3.e The Guard is responsible for ensuring that the tail lamp is present at the rear and that no other lamp is carried on any intermediate vehicle formed in a train.
- H3.f Where the train does not have a Guard the Driver is responsible for carrying out rule E3.d

### **H4 Train Brakes.**

- H4.a Passenger trains must be equipped throughout with a continuous automatic brake system in accordance with Section H.
  - H4.b Other trains or movements of vehicles must:
    - be equipped with brakes, providing sufficient brake power as will bring both portions of the train to a stop in the event of division of the train.
- OR
- where the brake power of the rolling stock cannot achieve this, additional braking or power must be provided by a locomotive at the rear of the train.
- H4.c Drivers of trains fitted with the continuous automatic brake system must use the train brake as the normal method of retardation.

### **H5 Couplings.**

- H5.a All vehicles in a passenger train must be connected to each other and to the train locomotive by means of Willison 'Buckeye' type couplings.

- H5.b Vehicles in other than passenger trains must be coupled by a means of Willison 'Buckeye' type couplings, bar or three-link couplings as appropriate, subject to each interconnection being compatible with the vehicles being connected.
- H5.c A three-link coupling may only be used where a bar coupling is not suitable. Where a three-link coupling is used, extreme caution must be exercised during any propelling movement.

**H6 Willison Couplers.**

**H6.1 Coupling Procedure.**

The couplers are designed to engage when vehicles are brought together and the following Rules must be observed: -

- H6.1.a Check that the couplers are in line. If locking pins are fitted, they must be in the 'Up' position.
- H6.1.b If the red Tail Lamp is still in place, locomotives must stop short and not couple up until the Tail Lamp has been removed by the Guard. (See above Rule H3.d).
- H6.1.c The Driver must move the vehicles together, avoiding undue impact, so that the couplers engage and the locking pin has dropped.
- H6.1.d The Driver must ensure that the couplers have engaged properly by reversing the locomotive and attempting to draw away from the train which has had its handbrake applied checking that the couplers hold.
- H6.1.e The Shunter must not couple the Brake Pipes until this test has been satisfactorily completed and the Driver's train brake valve is fully ON.

**H6.2 Uncoupling Procedure.**

- H6.2.a Before releasing the couplers, handbrake(s) should be applied or chocks positioned under the wheels of the vehicles to be uncoupled. Check that the Driver's train brake valve is fully ON and only then should the Brake Pipe be uncoupled. If necessary, the Driver may ease the vehicles together to slacken the couplers.
- H6.2.b Couplers fitted with locking pins are also fitted with release levers on both sides of the coupler. When the release levers are pulled, the locking pin can drop into the lower 'Down' position and lock the coupler open. When it is necessary to uncouple using this method, the coupler must be returned to the up position as soon as the vehicles have been parted.

**H7 Locomotive Whistle Codes.**

H7.a The following whistle codes apply on this Railway:-

1 short blast.	As an acknowledgement or clear of a point to be turned.
1 long blast.	To indicate that the locomotive is about to move.
2 blasts.	General warning (e.g. to warn persons on the line) and at level crossings
3 short sharp blasts repeated.	Signal from the Driver for the Guard to apply the brake van handbrake and air-brake.

**H8 Manning and Operation of Locomotives.**

- H8.a The Driver will be in charge of the locomotive at all times and the Fireman (when provided) must work to their direction.
- H8.b Unless the Driver of a visiting locomotive is qualified to the STRPS standard, that Driver must be accompanied at all times by a Conductor Driver who must be a fully qualified STRPS Driver.
- H8.c The Conductor Driver will be responsible for ensuring that the visiting Driver complies with the Railway's Rules, Regulations, and instructions at all times and must make themselves sufficiently familiar with the locomotive in order to apply the brake and bring the locomotive to a stand if necessary.

- H8.d No STRPS locomotive or other traction unit of any type shall be used on the STRPS unless it is known to be in a fit state to do so. This also applies to carriages and wagons.
- H8.e The STRPSPS Trustees are responsible for the certification of all locomotives and traction units that operate on the STRPS. This also applies to locomotives on loan to the STRPS.
- H8.f All STRPS locomotives will be given a thorough 'A' exam at the start of every season and a FTR (Fitness to Run) exam every steaming day thereafter. All 'A' / FTR exams will be fully logged and recorded.
- H8.g Drivers and fireman are expected to check their locomotive as they are preparing it for duty. In particular, before a locomotive leaves the shed the following tests must be carried out.
- Safety valves - lift at correct pressure.
  - Injector(s) - work correctly and pick up.
  - Gauge glass(es) - work correctly and give correct and equal readings.
  - Brakes - hand brake and steam brakes work correctly.
  - Steam locomotive water tanks must be filled at the running shed before the first train of the day.
- H8.h All tools and equipment issued for use on a locomotive must be safely stowed, eg fire irons, lamps, oil bottles etc. Coal must not be allowed to fall off bunkers or tenders and water filler lids should be securely closed.
- H8.i If a Driver considers a locomotive to be unfit for duty, he has the right to fail it and to ask for a replacement locomotive or to wait until his locomotive has been repaired and declared fit for duty again by a qualified examining fitter.
- H8.j Every STRPS locomotive has a file containing FTR sheets, boiler certification, driver's daily logs etc. Drivers are expected to fill in the log each time a locomotive is used to record, mileage done etc.
- H8.k Steam locomotive water tanks must be filled at Alston prior to each return journey to Slaggyford or any intermediate destination. This rule applies even if it is known that the water tank capacity is for more than one return journey. Failure to adhere to this rule may result in disciplinary action.
- H8.l The first steam locomotive service of each day will stop at the water tower before Kirkhaugh station and check that the water supply is operating and running clear. The water tower at Slaggyford may be used during the lay over to top up the locomotive tanks should the driver deem this necessary.  
There will be emergency hose pipes available at Alston and Slaggyford if the water supply at either water tower fails.  
  
It will be the responsibility of the DOM and the Slaggyford Crossing Keeper to ensure the hose supply is connected. and ready should it be needed.  
  
Steam locomotive drivers are responsible for ensuring that steam locomotive's water tanks are checked and topped up as necessary throughout the operating day.
- H8.m All STRPS steam locomotives must be driven and fired with due regard for the safety of the passengers and for the train and the locomotive itself.  
Due regard should be taken of weather conditions and braking should be carried out gently. Line speeds must always be observed and crews should avoid excessive blowing off, black smoke and use of the whistle.
- H8.n Locomotives and other traction units should only be driven by fully competent drivers with a current competency. Any driver asked to drive, or a fireman asked to fire, a type of locomotive with which they are not familiar must seek advice and should be offered familiarisation with that locomotive before he is expected to drive it.

H8.o No steam locomotive should be left unattended when it is in steam.

## **H9 Operation of Trains.**

- H9.a All trains must normally be hauled during running movements (i.e. a locomotive(s) must be marshalled at the head of the train and must pull the vehicles forming the train). The propelling of loaded passenger trains is PROHIBITED, except in an emergency.
- H9.b When trains are hauled by more than one locomotive ('double headed' and/or 'top and tail' working) the Driver of the leading locomotive must control the running of the train. Where trains are hauled by more than one locomotive, the rearmost locomotive always carries the token.

## **H10 Propelling of Trains.**

- H10.a Propelling can be hazardous as the locomotive is not at the leading end of the vehicles. However, it is sometimes unavoidable and accordingly must be carried out strictly in accordance with the Rules below.
- H10.b Other than as specifically authorised, propelling of a train requires the permission of the DOM and this must be according to the Rules in Section M 'failed trains. Unless totally unavoidable, passengers must not ride in carriages which are being propelled.
- H10.c Propelling of trains in the OTW on a downhill gradient is generally prohibited. In extreme circumstances and only when there is no alternative may propel on a downhill gradient be permitted by the DOM.
- H10.d When a train is being propelled, the Guard must ride at the front of the train and have access to the continuous brake. The Guard or Shunter must be in continual contact with the driver either by hand signals or by radio. The Guard or Shunter must have a whistle to warn persons on the track of the movement.
- H10.e All propelling movements must be limited to maximum speed of 5mph.
- H10.f If the propelling is for a short distance only (e.g. in a station), the Guard or Shunter may be positioned on the ground within visual or radio contact with the driver. If the propelling is within a station, the Guard or Shunter must warn persons on the platform of the move and ensure they stand clear. The Guard or Shunter should also ensure no persons alight from the train or attempt to board it while it is moving.
- H10.g When propelling, a white lamp must be displayed on the leading vehicle and a red lamp at the rear of the train. In hours of darkness or in poor visibility, these lamps must be illuminated.

## **H11 Facing Points.**

- H11.a All facing points within the route of a Passenger Train must be held securely closed and additionally held by means of a Facing Point Lock (FPL).
- H11.b Where the requirements of Rule E17.a cannot be achieved, the points must additionally be held closed by means of a point clamp. The point clamp must be secured with a padlock unless a Hand signalman is on site.

## **H12 Operation of Footpath and User-worked Accommodation Level Crossings.**

- H12.a Crossings of this type are protected by instruction notices for the user and Whistle Boards to alert Drivers of their approach.
- H12.b Additionally at crossings which may be used for vehicles or animals, a sign is displayed at the boundary gates advising the user of the crossing to telephone 01434 382070 and ask for the Signalman, before moving animals or long, slow or heavy vehicles over the crossing.
- H12.c If there is no approaching train, the Signalman may authorize the crossing user to proceed. The Signalman must then notify the train crew, before giving authority to approach, that such authority has been given and that extra vigilance should be used at that crossing to ensure that it is clear.
- H12.d If there is an approaching train, the crossing user must be advised that a train is approaching, it's estimated time of arrival, from which direction it will approach, and that the user should not start to cross until the train has passed.

A timed entry must be made in the TRB stating:

<p><i>Authority granted to cross with [enter "animals or abnormal load"] at [enter "Location"] Crossing, immediately after passage of [Up/Down train]. Time Signed</i></p>
--

### **Additional instructions in respect of passenger trains.**

#### **Rules additionally applying to passenger trains are identified by the prefix 'HA'.**

##### **HA1 General instructions for the Operation of Passenger Trains.**

- HA.1a A passenger train must be manned by a minimum crew of a Driver (Driver and Fireman on a steam locomotive) and a Guard.
- HA.1b The Guard must ride in a vehicle, suitable for the purpose, which must be equipped with a fully functioning handbrake capable of holding the train on all gradients on the Railway and a valve to apply the continuous train brake in an emergency.
- HA.1c The Guard is responsible for the preparation and correct formation of the train and that all vehicles are directly coupled by the Willison couplers and all brake hose connections are made between vehicles.
- HA.1d The Driver is responsible for ensuring that the locomotive is correctly coupled to the train.
- HA.1e The Driver and Guard are jointly responsible for ensuring that brake continuity tests are carried out in accordance with Rule I3.
- HA.1f The Guard is in charge of the train and is responsible for its safety and that of the passengers.
- HA.1g The number of passenger-carrying vehicles formed in any passenger train on the Railway must not exceed the number which can be accommodated within the platform length at the main stations.
- HA.1h It is permissible to exceed the length limit only in the event of an emergency, such as when a train might have to be used to effect recovery of a failed train or clear the line.
- HA.1i The Guard shall maintain a Logbook, with for instance: details of train departure and arrival times, reasons for delay, any out of course operating matters and any train defects.
- HA.1j Before departure of the first Passenger Train, the Guard shall carry out a radio test with the Alston Signalman, DOM and driver to check the equipment operation. This shall be recorded in the Guard's Log. Where appropriate, the Guard may use the radio to advise the Signalman that the train is ready to depart.
- HA.1k The Guard must agree with the Driver what is required if it is necessary for a train stopped in a station to be drawn forward or set back before departure. The permission of the signalman must be obtained for any such move. The Driver must not move the train until a hand signal is received from the Guard to commence the movement.
- HA.1l The Guard must ensure that all doors are closed, that any persons on the platform are standing well clear and that nobody attempts to join or leave the train before any movement is made. In order to carry out the movement as safely as possible, the Guard must obtain assistance from station (or other competent) STRPS staff or volunteer at busy periods.
- HA.1m Loaded passenger trains must not be set back unless it is necessary to move to within fixed signals or to enable the locomotive to start the train. Before any movement is made the Guard must warn all passengers to remain seated until the movement is complete.
- HA.1n During the journey the Guard and locomotive crew must keep a lookout along the train to ensure that doors remain closed and that no persons or bags, etc. are on the outside of the train.
- HA.1o In the event of noticing anything untoward the train should be brought carefully to a stand. If the Guard uses the emergency brake valve in the brake van to halt the train, great care must be exercised not to make too severe an application of the continuous brake.

## HA2 Formation of Passenger Trains.

The marshalling of passenger trains must be in accordance with the requirements of the Brake Rules in Section I.

- HA.2a A Passenger train must be formed of vehicles fitted with a continuous brake system in accordance with Section H, with the brake capable of being applied by either the Driver or the Guard. All passenger trains on the STRPS must be fitted with twin pipe continuous brake system and hauled by locomotives similarly fitted.
- HA.2b Passenger trains must be formed to include, as a minimum, **3** (three) passenger-carrying vehicles equipped with the continuous automatic air-brake. Where none of the coaches contain a compartment for the Guard equipped with a handbrake and a valve to apply the continuous brake, a separate brake van must be within the train formation as an additional vehicle.
- HA.2c Where the Locomotive(s) is / are fitted with the continuous automatic locomotive brake, a minimum of 2 (two) passenger-carrying vehicles equipped with the continuous automatic air-brake may be authorised, taking into account the weight of the train and the braking capabilities. This authorisation must be in writing by the DOM.
- HA.2d A brake van or the coach containing the Guard's compartment must normally be marshalled at the Down (north) end of each train formation.

## HA3 Passenger Train Dispatch.

Platform staff must be qualified in knowledge of governing Fixed Signals (Section C above) and Rules HA3.b – HA3.h (inclusive) below.

- HA3.a Trains must not be started before the time advertised in the timetable unless the DOM gives authority to do so.
- HA3.b Where no platform staff are on duty, the Guard is responsible for the despatch of the train (Rules HA.3c and HA.3e below).
- HA3.c If platform staff are on duty, they must ensure that before the signal to start is given to the Guard:
- All doors on the train are properly closed and secured and that no further passengers intend to join the train.
  - All persons on the platform are clear of the train and beyond the distance where they could be struck by a door coming open.
  - There is no part of the clothing of any passengers or bags etc. belonging to passengers hanging from or caught on the outside of the train.
- HA3.d When the checks in Rule HA3.c have been satisfactorily completed the platform staff must signal to the Guard by giving the 'all right' hand signal (one arm raised vertically) or by showing a white lamp signal that the train is ready to depart.

After receiving this signal from platform staff, the Guard must:

- check that any relevant fixed signals are cleared OR that, where necessary, permission has otherwise been received from the Signaller.
- signal to the Driver that the train is ready to depart by a Green Flag accompanied by two whistle blasts. The Driver may only start the train after receiving the 'ready to start' signal from the Guard. If necessary, platform staff must be prepared to relay this signal to the Driver.

- HA3.e As the train departs the Guard must maintain a sharp lookout along the platform until the whole of the train has cleared the platform and be prepared to apply the automatic brake to stop the train in the event of any untoward incident or on receipt of a hand signal from platform staff

Where the Driver is not on the platform side of the locomotive the Fireman must also carry out the duty of maintaining a sharp lookout.

- HA3.f Guard must observe the passing of the correct token or ticket by the Signaller to the Driver. This is particularly important on battery electric hauled trains and must be co-ordinated with keeping a lookout along the train until the whole of the train is clear of the platform.
- HA3.g As the train departs platform staff must maintain a sharp lookout along the platform and be prepared to signal the Driver or Guard to stop the train in the event of any untoward incident.
- HA3.h Before despatching the train, the Guard must ascertain if any passengers wish to alight at a request stop station and inform the Driver.
- HA3.i The train crew must proceed with caution when operating the first train of the day to ensure that the line is clear of obstructions. An obstruction is anything that in any way prevents the passage of trains. Possible examples could be lineside engineering work that encroaches onto the running line, a tree or a power line that has fallen across the line.

#### **HA4 Additional Instructions in respect of Dispatch of double-headed/ banked trains.**

The instructions in HA3 (above) are supplemented as follows:

- HA4.a HA3.d shall include a check that all Drivers are ready.
- HA4.b Where there is a rear locomotive provided, following completion of HA3.d, the Guard must face the rear Locomotives and give a green hand signal.
- HA4.c The rear locomotive(s) respond with a whistle.
- HA4.d On receipt of the rear locomotive whistle(s), the Guard shall turn to face the leading locomotive and gives the flag and whistle signal as usual, ensuring that this is visible to all Drivers of locomotives at the front of the train.
- HA4.e The second (and subsequent) Driver of the front locomotive(s) shall give a whistle to notify the Driver of the leading locomotive to pull away.

#### **HA5 Request Stops at Unmanned Stations.**

- HA5.a The unstaffed stations at Kirkhaugh and Lintley are treated as request stops. Trains will only stop when passengers on the train have informed the Guard that they wish to alight or when passengers are waiting at these stations to join the train. The Guard will have informed the Driver before despatching the train of any passengers wishing to alight at Kirkhaugh or Lintley (EA3.h above).
- HA5.b Drivers must keep a sharp lookout on the approach to these stations for passengers waiting to join the train and be prepared to slow accordingly and stop the train within the platform.
- HA5.c The Guard should remind the Driver of passengers wishing to alight on the approach to these stations. If the Guard is in visual contact with the driver, this may be by hand signal or display of a red flag. If the Guard is not in close visual contact with the Driver, this may be by radio contact or by displaying the red flag out of the side of the Guards van. In the latter case, the Guard and the Driver must agree where and from which side of the train this will be done.
- HA5.d In the absence of any signal as in HA5.c above, the Driver must slow the train and bring it to a stand within the station platform.
- HA5.e In the event that the train stops at any of these stations, the Driver may only restart the train on the signal from the Guard of a green flag and two blasts on the locomotive whistle.
- HA5.f The Guard must inform the Alston signaller that the train is at any of these stations, regardless of whether it has stopped or is passing through. In the case of down trains at Lintley, this message must also be passed to the Slaggyford Crossing Keeper.

## **HF Additional Instructions in respect of Freight Trains.**

Rules additionally applying to freight trains identified by the prefix 'HF'.

- HF.a The DOM must manage the operation of all freight trains on days when a passenger service is planned to operate where they are part of a timetabled working, , e.g. a gala event. Any additional freight trains on operating days can only be authorised by the DOM.
- HF.b The Engineering Supervisor may authorise the operation of freight trains on non-passenger train operating days when a DOM is not on duty.
- HF.c Freight trains are not permitted to carry passengers.
- HF.d Freight trains must convey a brake van, in which the Guard must ride. The brake van must always be marshalled at the rear of the train.
- HF.e STRPS staff & volunteers are only permitted to ride on a suitable vehicle.
- HF.f The Guard is responsible for ensuring that the train is safely coupled, that all doors are closed and loads properly secured, and that the train is complete with tail lamp. When conveying any loaded vehicles in a freight train, the contents of the wagons must be loaded within the structure of the wagon and within loading gauge. If any loads cannot be contained in this way the train must run as a works train and in a possession. When the Guard has satisfactorily completed these checks, and where appropriate, checked fixed signals, the Driver may be given a signal that the train is ready to depart (one arm raised in 'All right' – see above C15 - with two whistle blasts). A green flag is only used for passenger trains. The Driver must not start the train until he receives a hand signal from the Guard,
- HF.g During the journey the Driver (and Fireman if there is one) must regularly look back along the train to ensure that it is following correctly.
- HF.h If the Driver notices anything amiss the train must be stopped as soon as it is safe to do so.
- HF.i In the event that the train is brought to a stand intermediately, the Driver must not restart until a hand signal has been received from the Guard indicating that it is safe to do so.
- HF.j The Guard must be prepared immediately to apply the handbrake to assist in securing the train if it is brought to a stand.

## **SECTION I – RULES FOR THE USE OF THE CONTINUOUS AUTOMATIC AIR-BRAKE.**

The purpose of this section is to explain the working of the automatic air-brake system and the procedures for its preparation for service and use. All passenger trains on the STRPS use the Twin-Pipe continuous automatic air-brake system. This includes all locomotives which are used for passenger trains. All freight and non-passenger locomotives and vehicles use the Single Pipe system. It is permitted for Twin-Pipe fitted locomotives to operate Single Pipe vehicles, using a special adapter for this purpose.

Locomotives fitted with only Single Pipe automatic airbrakes **MUST NOT** be used on passenger trains which have the Twin Pipe system.

### **I1 Description of the Twin Pipe System (as used on all Passenger trains).**

- I1.a The Twin Pipe consists of a RED pipe and a YELLOW pipe. The compressor on the locomotive charges a reservoir in each vehicle via the RED pipe, when the automatic brake can be operated. The air in this pipe is supplied at 85 psi.
- I1.b Emptying the RED pipe by whatever means will apply the brakes in all vehicles and stop the train. Apart from the Driver applying the train brake from the footplate, this can be done by
- opening the emergency valve in the guard's van.
  - operating an emergency brake valve handle in any coach.
  - opening the cock on the RED pipe at the rear of the train.

The brake is also automatically applied if the vehicles in the train become separated due to the failure of a coupling, as the train parts and the flexible hose connections are separated.

- I1.c The YELLOW pipe supplies air to the brake cylinders from the driver's train brake valve through all vehicles connected by flexible hose connections.
- I1.d When the automatic air brakes are released, air is only charged in the RED pipe and the Yellow pipe is empty. When the Driver operates his train brake valve, air is transferred to the YELLOW pipe which allows compressed air to pass to the brake cylinders, thus applying the train brakes. When the brakes are released by the Driver, air pressure is reduced in the YELLOW pipe which releases air in the brake cylinders and the RED pipe is charged again to 85 psi.

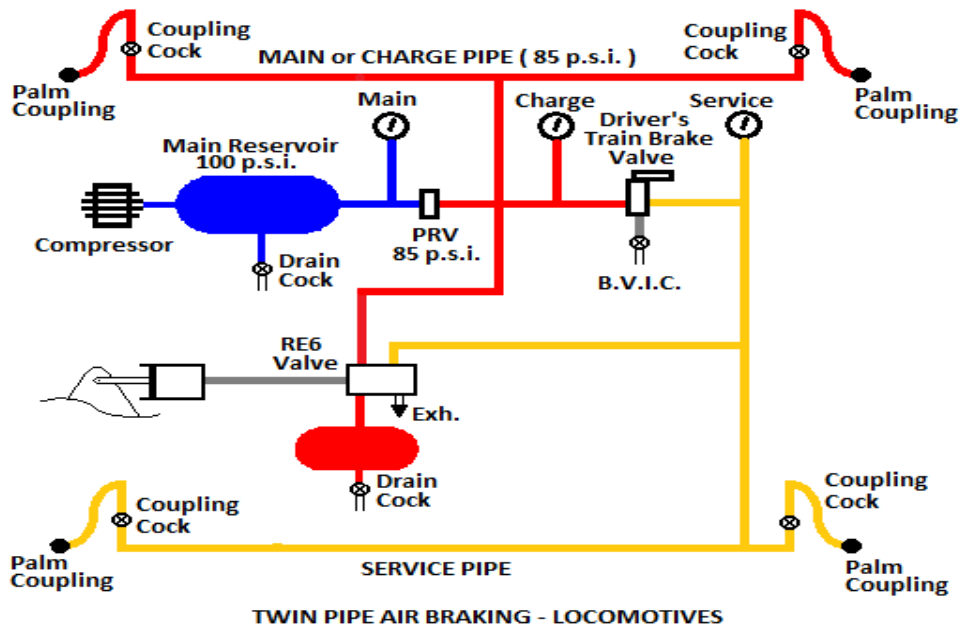

## I2 Preparing a Continuously Braked Train for Service (for Both Twin Piped and Single Piped formations).

At the start of the day's duty the person preparing a passenger train must follow the procedures below:

- I2.a Ensure that all flexible hoses between vehicles are correctly connected. In twin piped train formations, it is important that the flexible hoses are correctly aligned, i.e. Red to Red, Yellow to Yellow.
- I2.b Ensure that all intermediate train pipe cocks on the flexible connections between vehicles are open and that the cock(s) at the rear of the formation is closed.
- I2.c Check that all vehicle isolating cocks are open (in order to ensure that the vehicle reservoir can be charged with air).
- I2.d Check that all reservoir drain cocks are closed (in order to ensure that the vehicle reservoirs will maintain the required air pressure).
- I2.e When connecting the locomotive to the train, open the cocks on the end of the formation BEFORE opening the cocks on the locomotive. As the train pipe is pressurised, listen for audible air leaks.
- I2.f The continuous brake on each vehicle must be observed to be operating correctly by conducting a brake test as in I3 (for Twin Piped trains) or I5 (for Single Piped trains) below before the train is allowed to enter service.
- I2.g ONLY once a brake test has been satisfactorily carried out may any vehicle handbrakes be released.
- I2.h When the train locomotive is attached to the train, once the Willison coupling has been tested by the locomotive moving slightly away from the train, the coupling cocks between the locomotive and the front coach must be opened. It is important to open the cocks on the coach first before opening the cocks on the locomotive to avoid undue pressure on the flexible hoses.
- I.2.g If two or more locomotives are coupled in the train, only the FRONT locomotive may control the braking. The Driver(s) of the other locomotive(s) must isolate the brakes by the handle in the locomotive cab (See I7 below).

## I3 Brake Test on Twin Piped Trains.

- I3.a When a train is first marshalled, a FULL brake test must be carried out, as described below. The Guard must ensure that all handbrakes are applied.

- I3.b The Driver must apply the train brakes. The Guard must ensure that the pressure on both the RED and YELLOW line gauges are both at 85 psi. The Guard must then walk the length of the train, observing that all brakes are applied on each axle.
- I3.c The Guard must ask the driver to release the brakes. At the rear of the train, the Guard must remove the YELLOW pipe from its bracket and open the coupling cock and ensure there is no air in the pipe. He/she must then signal "All Right" to the Driver.
- I3.d The Guard must then remove the RED pipe from its bracket and hold it firmly before opening the coupling cock. Air will be released rapidly and the Guard should wait for approximately 5 seconds before closing the cock. The Driver must observe the falling pressure in his RED line gauge. The Guard must then signal the Driver "All Right".
- I3.e The Guard must then signal the Driver to apply the train brake using the "Make Air" hand signal (C.18). The Guard must then release the YELLOW hose and, holding it tight, open the cock and check for air being exhausted from the pipe. This confirms the continuity of the Yellow line. The Guard must then close the cock and connect it to its bracket. The Guard must then signal the Driver "All Right" which will be returned by the Driver. The Guard must observe that the brakes on the rearmost vehicle have been released. This completes the full brake test.
- I3.f A full brake test is required if any additional vehicles are added to the train, a coach removed from the train, or when a locomotive is removed from the train and re-joins the train after a "run round" at either Slaggyford or Alston
- I3.g During the journey, Drivers must carry out a running brake test on the first movement of the day, if there has been a change to the braking power of the train (e.g. an additional vehicle added, isolation of the brakes on a vehicle or brake adjustment). The driver must ensure this satisfactorily decelerates the train.

#### I4 The Single Pipe System.

The single pipe system is only in use on the STRPS's infrastructure works train and associated locomotive and rolling stock.

The single pipe system is connected throughout the train by a single pipe, the fittings on which are RED. A compressor on the locomotive (or associated compressor tender) charges a reservoir, which supplies air to the system via the Driver's brake valve. Once that reservoir has been charged to the full train pipe pressure (minimum of 80 psi) the automatic brake will be able to operate on that vehicle.

Each braked vehicle also has a triple valve which senses any change in the air pressure in the train pipe. This enables it to control the passage of air between the train pipe, the reservoir, and the brake cylinder(s).

It is important to understand that the continuous brake will not operate on a vehicle if there is no reserve of air pressure in that vehicle's reservoir.

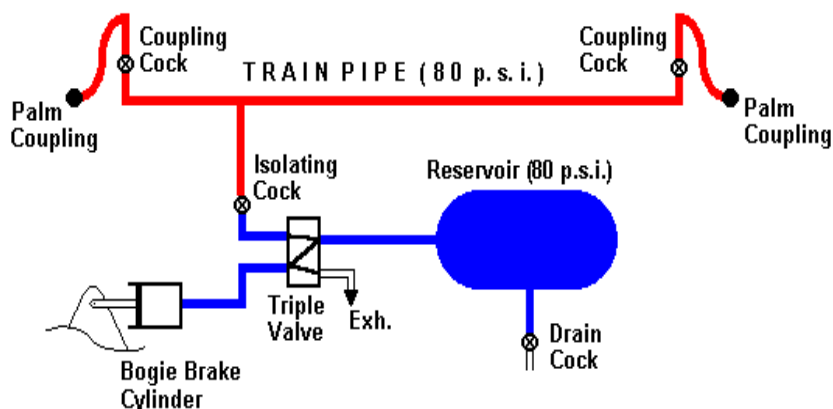

- I4.a So long as the reservoir is fully charged, the train brakes are released. A reduction in pressure in the train pipe allows air to pass from the reservoir to the brake cylinder and applies the brake.
- I4.b Recharging the reservoir by the driver releases the brake cylinders and brakes.
- I4.c The continuous brake can be applied throughout the train by any action which reduces the train pipe pressure e.g. the Driver's brake valve, the Guard's emergency brake or a break in the continuity of the system, such as parting of flexible hoses.
- I4.d As with the twin pipe system, partially reducing the pressure in the train pipe allows a partial application of the train brakes which slows the train eg on approaching a station or a signal at danger.  
The air-brake is applied to EVERY braked vehicle on the train and is far more powerful than the handbrake and will hold a train perfectly well on a gradient as long as reservoir air pressure is maintained.

## **I5 Brake Test Procedure for Single Piped Trains.**

- I5.a The Driver must apply the brake throughout the train and the Guard must observe that the brakes on each axle of the train are on.
- I5.b The Guard must signal the Driver "Make Air" as in C18 to release the brakes. The Guard must then remove the flexible hose from its bracket and, holding it tight, open the coupling cock to release air for approximately 5 seconds. The Guard will hear a 'clunk' as the brakes come on. The Driver must observe the drop in train brake pressure on the gauge in the locomotive cab.
- I5.c The Guard after closing the cock and restoring the flexible hose to its bracket must exchange "All Right" signals with the Driver. The Guard must observe that the brakes on the rearmost vehicle have been released.
- I5.d Once a satisfactory brake test has been conducted, all handbrakes in the formation must be released.

## **I6 Definitions.**

- I6.a A 'continuously braked' (commonly referred to as simply 'braked' or 'fitted') vehicle is one which is equipped with the automatic air-brake system.
- I6.b A 'piped' (or 'pipe only') vehicle is one which provides a through connection of the train pipe but which is NOT equipped with the continuous automatic air-brake system.
- I6.c An 'unfitted' vehicle is one which is not equipped with either the automatic air-brake system or a through pipe.

## **I7 Double-Heading and Banking of Trains.**

- I7.a Both locomotives must always be fully coupled to the train and air pipes connected with intermediate cocks open. Banking with a loose (i.e. uncoupled) locomotive is NOT permitted.
- I7.b The leading locomotive is always responsible for the normal braking of the train. To this end, the leading locomotive must be the only one supplying air to the train pipe. To ensure that this is the case:
  - i) close the brake valve isolating cock (BVIC) on both locomotives.
  - ii) apply and release the train brakes on the second (etc.) locomotive(s). The train pipe pressure should fall to zero and not rise again.
  - iii) open the BVIC on the leading locomotive (only).
  - iv) release the train brakes on the leading locomotive. The air pressure should be seen to rise to 85 psi (twin pipe) or 80 psi (Single Pipe) on the gauges on both/all locomotives and the brake van. The brake continuity test must then be carried out.
- I7.c In emergency, the second locomotive may charge the train pipe. During the brake continuity test, the Guard must agree with the Drivers of both / all locomotives that the test was successful. This is permitted for one journey only to where the authorised arrangements can be resumed.

Under such circumstances, the Driver of the locomotive supplying the air must watch the train gauge, and if the lead loco applies the brake, he must cut the air immediately, to prevent train brake overrun.

### **I8 During the Journey.**

- I8.a Drivers must carry out a running brake test (in order to ensure that the automatic brake is working properly) during the first movement of the day and after any change to the brake power of the train (e.g. addition of a vehicle, isolation of the brakes on a vehicle, or brake adjustment).
- I8.b The Driver must ensure that satisfactory deceleration occurs when a running brake test is made.
- I8.c If the Driver or Guard observes any irregularity in the operation of the brake, the train must be stopped in order to investigate the fault.
- I8.d In the event that it is necessary to isolate the continuous brake on any passenger-carrying vehicle(s) whilst in service it must be understood that the braking power of the train will be reduced and Drivers must adjust the speed of the train accordingly.
- I8.e The Driver must not commence any journey, or restart from any stop made to investigate or rectify any problem with the continuous brake, until satisfied that the continuous automatic brake is operating correctly and it that a subsequent brake test has been carried out.
- I8.f The Guard must not give the signal that a train is ready to start until satisfied that the testing of the continuous automatic brake has been successfully carried out.

### **I9 Disposal of a Continuously Braked Train or Vehicle at the end of the Working Day.**

- I9.a At the end of the day's duty the person carrying out the disposal of the train or vehicle must open all reservoir drain cocks; the cocks must be closed after the reservoir has exhausted all air.
- I9.b One wheel set on each rake of coupled vehicles must be chocked unless a hand brake fitted vehicle forms part of the rake, in which case the hand brake must be applied.

### **I10 Attaching a Dead Locomotive to a Passenger Train.**

- I10.a If necessary, a dead locomotive may be attached to a passenger train provided that the brakes have not been isolated on any passenger-carrying vehicle formed in the train.
- I10.b The dead locomotive must carry a person qualified to operate its brakes unless the dead locomotive is fitted with an emergency train braking system and provided that emergency train braking system has been tested and found to be operating correctly.

### **I11 Personal Safety when Handling the Flexible Brake Pipe Hoses.**

The train pipe contains air at high pressure and great care must be taken when handling the flexible hoses. The following precautions must be taken when coupling or uncoupling the hoses: -

- I11.a When coupling, ensure that the hose ends are clean, that the train end cocks are closed and that the Driver's train brake valve is fully ON before opening the intermediate cocks.
- I11.b When opening intermediate cocks, first open the cock remote from the locomotive.
- I11.c When uncoupling, ensure that the train pipe pressure is reduced to zero (i.e. Driver's brake valve is fully 'ON'), and that the coupling cocks are closed before breaking the coupling hoses.

## **SECTION J – SHUNTING INCLUDING DUTIES OF STRPS STAFF & VOLUNTEERS.**

The purpose of this section is to explain how shunting must be undertaken in a safe and well-regulated manner. This is in order to minimise potential risk to STRPS staff & volunteers involved in the task or working nearby and derailment of or damage to vehicles being shunted. On days when a passenger train service is operating the DOM must authorise all shunting operations that will entail the use of the main line, other than that in connection with the planned operation of passenger trains (although the responsibility for safe practice stays with the Shunter).

### **J1 Personal Safety when carrying out Shunting Work.**

Shunting involves numerous hazards to personal safety. The preferred method of communication between Shunter and Driver is by radio. Both the shunter and Driver must be in possession of a handheld radio and perform a radio check before any shunting movement is started. However, hand signals may be used subject to agreement between the Shunter and Driver so long as they remain in visual contact and have agreed eg where the signals may be given from a different position if the movement could result in loss of visual contact. Before any movement is made, the Driver and Shunter must agree on what means of communication will be used.

- J1.a All STRPS staff & volunteers undertaking shunting duties must take extra care to minimise the number of occasions on which they cross lines or have to pass close to rail vehicles and when they are walking alongside lines and sidings.
- J1.b Use of the term 'Shunter' means the person in charge of the shunting work. All persons acting as 'Shunter' must be qualified as Railwayman 2.

### **J2 Signals and Radio Communication.**

- J2.a Shunting is controlled by means of radio communication (the preferred method) or hand signals between the Shunter and Driver. Hand signals must be given clearly in accordance with Section C.20. By radio, the Shunter must continuously inform the Driver of the approximate distance between the locomotive and the vehicle(s). When the couplers engage the Shunter must say "STOP STOP STOP".
- J2.b Shunters must observe and comply with the working of fixed signals when shunting is taking place on a line provided with such signals.
- J2.c Shunters must not give any sort of 'proceed' hand signal or instruction if this will conflict with the indication given by any fixed signal applicable to the movement they intend to make.
- J2.d Drivers are not relieved of their responsibility to observe and obey the indications given by fixed signals when they are working to hand signals or radio Instructions given by a Shunter.
- J2.e When radio communication is used to control a shunting movement, the Shunter must talk continuously to the Driver at intervals of not more than 10 (TEN) seconds. Drivers must immediately halt the locomotive/movement if at any time they lose sight of or communication with (if using portable radios) the Shunter controlling that movement. The locomotive must not be moved again until the proper hand signal or radio instruction to do so has been received from the Shunter.
- J2.f Drivers must arrange with the Shunter when using hand signals as to which side to look out and when to change over so that their line of sight is maintained.
- J2.g Shunters must NOT keep the transmit button continuously pressed as this prevents other users transmitting.
- J2.h During propelling of a continuously braked train, which has a brake valve in / attached to the leading vehicle, the Shunter may travel in that vehicle and once the start signal has been given from within the vehicle, the Shunter should control the brake in lieu of the need to maintain continuous sight.

Before a movement is commenced under this clause, a full brake test (from the Guards portable propelling brake valve where utilised) must be carried out.

### **J3 Prior to Starting Work.**

- J3.a Before commencing any shunting work or movements the Shunter must agree with the Driver exactly what work will take place and the order in which it will be carried out. If using portable radios, the Shunter and Driver must perform a radio check. If using hand signals, the Shunter must ensure the Driver knows in advance where he/she will be positioned.

### **J4 Preparing Vehicles for Shunting.**

- J4.a The Shunter must prepare vehicles prior to shunting them, ensuring that there are no cables or other connections loose or hanging from the vehicle and that all doors are closed and secured.
- J4.b Couplings on vehicles should be made ready for attaching prior to the arrival of the locomotive on the line on which the vehicle is standing. If any vehicles have a continuous automatic brake, the flexible cables between vehicles must be properly connected and intermediate air cocks open (see FI5.g).
- J4.c Where applicable vehicle handbrakes must be 'on' when the locomotive attaches.

### **J5 Attaching the Locomotive to the Vehicles to be Shunted.**

- J5.a There must be a gap of at least 20ft between any vehicles or locomotive to be attached if the Shunter needs to go between them and the Shunter must ensure that the Driver understands that no movements may be made until the Shunter's work between has been completed.
- J5.b After checking that it is safe to attach the locomotive the Shunter shall hand signal the Driver that it is safe to continue to move the locomotive up to the vehicle to attach.
- J5.c As the locomotive moves towards vehicles, the Shunter must indicate the distance between the locomotive and the vehicle(s). This may be done by hand signals (Section C13 to C21).
- J5.d The Shunter must not go between vehicles including between the locomotive and vehicles (eg to couple/uncouple air hoses or couplings) until the Driver has said it is safe to do so and that no movement of the locomotive or vehicles will be made.
- J5.e Extra care must be taken if it is necessary to go between vehicles on a significant gradient.
- J5.f The Shunter must only attach the locomotive to the vehicles to be shunted using the approved couplings. The use of props, chains, ropes, or any form of loose shunting is strictly forbidden.
- J5.g If the locomotive cannot be properly coupled, the vehicle must be moved by hand to a suitable location for it to be properly coupled.
- J5.h If the vehicles to be shunted are equipped with the continuous automatic air-brake this must be connected.
- J5.i The Shunter must **NEVER** go between a platform and the train to perform any coupling or uncoupling operations.
- J5.j The Shunter must **NEVER** go between vehicles and a buffer stop. Always go round the buffer stop.

### **J6 Before Making Any Movement.**

- J6.a The Shunter must, before giving the Driver a hand signal or instruction to make any movement, ensure that all hand worked points (included trailing points) are correctly set for that movement and ensure that all handbrakes on those vehicles have been released.
- J6.b Ensure that the route is otherwise clear of any obstruction, STRPS staff & volunteers, etc. and is otherwise safe to run over and is free of obstructions.

### **J7 During Shunting Movements.**

- J7.a The Shunter must keep a sharp lookout ahead of the movement at all times, being prepared to instruct the Driver to stop short of any obstruction, either by hand signal or by radio.

- J7.b If hand-held radios are used by the Driver and Shunter for communication, the Shunter must talk continuously to the Driver at intervals of not less than 10 seconds.
- J7.c If the Driver ceases to hear continual instructions from the Shunter, the movement must be stopped immediately until the Shunter instructs the Driver to continue with the shunt movement.
- J7.d Should a movement be brought to a stop, the Shunter must ensure that it is safe to continue before signalling the Driver to restart the movement at slow speed.
- J7.e The Shunter must not ride on any vehicle other than one which has a place where it is safe to ride within the loading gauge of the vehicle and from where the Shunter has both a view of the line ahead and can maintain visual or radio contact with the Driver. No one should attempt to board or alight from a moving train.

### **J8 Before Entering a Building or an Area with Limited Clearance.**

- J8.a The Shunter must ensure that before, permitting a movement into any building, all STRPS staff & volunteers in that building have been warned to keep clear and that the line is clear and safe to run on for as far as the movement needs.
- J8.b The Shunter shall also ensure that before permitting a movement to enter a building, all equipment, tools and cables, etc. are clear of both the line over which the movement will be made and the area through which he will walk while in control of the movement.
- J8.c All shed doors should be opened sufficiently to allow the shunting move to take place safely and all doors should be secured back to prevent them from blowing in to the side of the moving train.
- J8.d At night or when shunting in poor weather conditions an illuminated red light should be placed on the ground facing the driver as a reminder that the shunter is in between.

### **J9 Detaching the Locomotive or Detaching between Vehicles.**

- J9.a After the movement has been brought to a stand the Shunter must advise the Driver exactly what is intended and have the Driver's assurance that there will no movement of either the locomotive or vehicles until instructed or signalled to do so by the Shunter.
- J9.b Before detaching any vehicles the Shunter must first ensure that they have been properly secured by means of the handbrake (or in the case of coaches the air has been dumped and the brakes are hard on) or, where necessary, by means of wheel scotches.
- J9.c After detaching, the Shunter must signal the Driver to draw a short distance clear of the vehicles and must then ensure that the vehicles do not move before the locomotive proceeds to other work.

### **J10 Persons Relaying Hand signals.**

- J10.a Any person who relays hand signals between the Shunter and the Driver must be qualified as 'Railwayman 2'.
- J10.b When a second person assists the Shunter in the relaying of hand signals, or any other tasks specified to be carried out by the Shunter, the Driver must be informed as to which person is in charge of the movements.

### **J11 Shunting and Passenger Trains.**

- J11.a The formation of Passenger trains is covered in Rules HA2 above.
- J11.b Shunting towards loaded passenger trains is not permitted except in order to attach the locomotive(s) which will work the train. An additional empty coach may be added to/detached from a loaded passenger train provided that the loaded coaches are not moved and that there are no passengers in that coach.
- J11.c Shunting of loaded passenger trains is not permitted except in an emergency with the permission of the DOM.

J11.c Shunting of loaded passenger trains is not permitted except in an emergency with the permission of the DOM.

A passenger train at a platform may be propelled backwards to be wholly behind the fixed starting signal.

Persons on the platform must be informed of the move, told to stand clear and not attempt to board the train and passengers on the train informed and told not to attempt to leave the train during the movement.

## **SECTION K – TRAIN DETAINED AT A SIGNAL.**

- K1a. Where a train is detained at a signal the driver must immediately contact the signalman unless he is in possession of the token.
- K1b. If the train is detained for more than two minutes the driver **MUST** contact the signalman by: using the radio that is provided or sending the fireman on foot.
- K1c. In conditions of poor visibility, e.g. falling snow or thick fog, the driver must contact the signalman by radio immediately.
- K1d. If the signal clears the driver must make sure that the fireman has re-joined the train before he moves off.
- K1e. When the driver contacts the signalman or when the fireman reaches the signal box the following information must be relayed.
- The identity of the person speaking.
  - The signal at which the train is being held.
- K1f. The purpose of this exercise is to remind the signalman that he has a train standing at his signal - this prevents him from allowing another train in-to the occupied section. The signalman will use a reminder appliance to remind himself of the position of the train in section.

## **SECTION L**

**NOT USED**

## **SECTION M - ACCIDENTS, OBSTRUCTIONS & FAILURES.**

### **M1 Accidents.**

In the event of an accident the priorities must be as follows:-

- M1.a Make the site and the train secure.
- M1.b Protecting the obstruction.
- M1.c Protecting other trains if applicable.
- M1.d Obtaining help from the emergency services.
- M1.e Assistance for the injured.
- M1.f Protection of evidence.
- M1.g Clearing the line.
- M1.h In the event of a member of the train crew being injured and being unable to carry out their duties, any other member of STRPS staff or a volunteer who is deemed competent, must carry out those duties as far as they are able.
- M1.i If a train is immobilised by a collision or a derailment the driver and guard must first secure the train so that no further damage can result. The locomotive controls must not be operated after an accident has occurred except where necessary to do so to secure or protect a train. If the controls do need to be moved the person doing so must make a note or take a photograph of the original position of the controls and pass the information or images to the DOM.

### **M2 Protection due to Obstructions.**

An obstruction is anything that in any way blocks the passage of trains. Possible examples could be lineside engineering work that encroaches onto the running line, a tree or a power line that has fallen across the line. The nature of such obstructions and the danger they might pose means that they are subject to a slightly different protection arrangement from that used for a failed train.

Extreme care must be exercised if a power line fouls the railway line.

Minor obstructions, such as a number of branches from a tree partially blocking the line, may be dealt with by the person or crew of the train discovering it. Once the minor obstruction has been removed, normal operation may be continued.

- M2.a The method of investigation where an obstruction is suspected should be appropriate to the form of the obstruction.
- M2.b A train must NOT be used for initial inspection where it is suspected that power lines are down.
- M2.c If an obstruction is discovered, the Signaller must be advised immediately, who must take any necessary action to prevent the further passage of trains towards the obstruction.
- M2.d The signaller must ascertain if the obstruction has been protected, by means of a red flag or target sited, or a red lamp in reduced visibility, at least 100 yards from it on the side from which trains are likely to approach. The Signaller must also record the details in the TRB and apply appropriate reminder appliances, advising the DOM accordingly.

- M2.e The DOM must be informed of the extent and nature of the obstruction and make arrangements for the obstruction to be removed to enable the resumption of train services. If the nature of the obstruction is such that specialist equipment and contractors would be required, the DOM must assess whether passenger train operation could be resumed later in the day or whether services must be abandoned until the obstruction can be dealt with.
- M2.f If the obstruction has been discovered by an approaching passenger train, the DOM must make arrangements for the train to return to its originating station. If possible, a light locomotive may be despatched to enable a Down train with passengers on it to be hauled back to Alston, as for the recovery of a failed train (M4 below), rather than the train engine propelling the train.
- M2.g When the obstruction has been removed the PICoW in overall charge of the site must advise the Signaller accordingly and confirm that the line is now clear of the obstruction. Where a possession has been taken in connection with the obstruction this must be given-up in accordance with Section T.
- M2.h The Signaller must make a suitable entry in the TRB to the effect that the obstruction has been removed and advise the DOM accordingly.
- M2.i The DOM must record the details of the removal of the obstruction in the Logbook and, when necessary, post a suitable notice on the Signing-On Notice board.
- M2.j The PICoW in charge of the site at the time the obstruction is removed will be responsible for removing the protection and returning the equipment used.
- M2.k Red flags, targets and lights suitable for protecting an obstruction are kept in Signal Boxes and Brake vans. They must be examined regularly to ensuring that they are in good condition and available for immediate use. Any problems or defects must be reported to the DOM who must ensure repair or replacement.
- M2.l Where there is no Signaller on duty, the senior person on site should arrange for those actions to be undertaken.

### **M3 Examination of the Line.**

- M3.a Ideally, the line should be examined before use. If this is not possible, the Driver of the first scheduled train must observe carefully ahead for any defect in the permanent way (e.g. missing fishplates) any obstruction of the line, such as fallen trees or branches. If these cannot immediately be cleared, the Driver or Guard must report the defect to the Alston Signaller, who must inform the DOM, and arrangements must be made to examine the line.
- M3.b A light locomotive or locomotive and brake van may be used, at caution, if large animals (e.g. cows or horses) are reported to be on the line or if there is any doubt about the integrity of the line to pass trains safely.
- M3.c The Driver of the locomotive or train used to examine the line must be in possession of the OTW token or ticket and must be instructed to proceed with caution prepared to stop short of any obstruction.
- M3.d No other train or movement must be permitted to enter the Section until either:
- The line has been reported to be clear and the locomotive or train carrying out the examination has left the section and the Driver has given up the OTW token or ticket, in which case the line is open for normal operations.
  - The locomotive or train carrying out the examination has left the section and the Driver has given up the OTW token or ticket, but the line is still blocked. In which case only works trains are allowed for the purpose of clearing the line.
- M3.e If a locomotive is taken from a train at an (unmanned) intermediate location and the locomotive is dispatched to inspect the line the Driver must be in possession of the token or ticket and a means of communication. The train must be secured by means of all handbrakes and by dumping the air from the continuous automatic brake. The Signaller must also be informed. If the train remains in the OTW Section, the Signaller may authorise that locomotive to return to the train provided it has been confirmed that the whole of the affected area has been examined. The Signaller must instruct the Guard, that the train may subsequently depart.
- M3.f If the line is found to be obstructed that obstruction must immediately be protected in accordance with Section M

## M4 Failed Trains.

The definition of a failed train is where either the locomotive fails for mechanical reasons or a defect of one or more of the vehicles in a train (e.g. by derailment) prevents the train continuing to its planned destination without outside intervention. For example, if a steam locomotive temporarily loses steam pressure which can be built up again after attending to the fire, this is NOT a failed train as, once steam pressure is built up, the train may continue its journey.

- M4.a In the event of a train coming to an unscheduled stop in the OTW Section due to the discovery of a defect in the train, the Driver and Guard must confer and, if the train cannot be moved under its own power for any reason, it becomes classed as a failed train and the following procedures MUST BE implemented to arrange recovery of the train.
- M4.b In the event that injury to any passengers, STRPS staff, or volunteers has occurred or is likely to occur (e.g. a coach catching fire), the emergency services must be called at the earliest opportunity via the Signaller at Alston in accordance with the emergency plan. (SMS Section 10)
- NB Any such messages by radio or telephone must start with the words "This is an emergency call".
- M4.c The Driver and Guard must ensure that the train is secured using all available handbrake power in addition to the automatic brake system.
- M4.d The Guard must place protection of the train by means of a red flag (and additionally a red light in times of poor visibility) in the direction from which assistance is likely to come. It would be normal for an assisting locomotive to be sent from Alston but if there is a possibility of assistance coming in the Up direction from Slaggyford (e.g., if two train running is in operation) protection must be placed both in front of and in rear of the train. The red flag (and red light when used) must be placed at least **100yds** from the train in a position where they will be clearly visible to the Driver of an approaching locomotive for at least a similar distance. The Guard is responsible for placing the protection but if the train is hauled by a steam locomotive, the fireman may be used to place protection in front of the train. In the event of the Guard not being available, the Driver or Fireman should undertake that duty.
- M4.e The Guard must use the radio provided to inform the Alston Signaller and, if the train is travelling in the Down direction to Slaggyford, the Slaggyford Crossing Keeper of the failure of the train. The Guard must provide the following information:
- The location of the train (this should be by reference to bridge numbers, lineside mileposts or named locations e.g. station name).
  - Whether it is an Up or Down train.
  - The type of train and the reason for failure.
  - Assurance that the train will not be moved, even if it subsequently becomes possible for the train to be moved under its own power.
  - Assurance that the required protection has been put in place. The Signaller will advise from which direction assistance will come and the Guard / Fireman may remove the protection placed for the opposite direction.
- M4.f The Alston Signaller must immediately inform the DOM who must authorise the despatch of a rescuing locomotive or train. The DOM must consider the reason for the failure and whether the failed train may simply be hauled back to Alston by a rescuing locomotive or whether a more serious occurrence (e.g. derailment) will demand more complex intervention and whether that might cause more significant delay to subsequent services or whether the services for the remainder of the day need to be cancelled.
- M4.g If the failed train is recovered by a rescue locomotive, the DOM. authorises the section signal 14 to be passed at danger and the Signaller must record this in the TRB which the DOM countersigns. The Signaller must instruct the Driver of the rescue locomotive that they may pass signal 14 at danger and inform them of the location of the failed train and that the rescue locomotive must stop at the protection, where the Guard will meet the rescue locomotive and guide it onto the failed train. The Signaller must then inform the Guard when the assisting locomotive has been despatched. The Guard must then walk to the protection to meet the assisting loco.
- M4.h Great care must be exercised that all the radio messages and instructions concerning a failed train situation are clearly understood and the recipient must repeat back what they have been told to ensure this.

- M4.i The Guard must at the earliest opportunity inform passengers the reason for the delay. It may be necessary for the Guard to arrange with the DOM for any passengers to be rescued by other means if they do not wish to remain in the train until a recovery is affected. Passengers may if they wish leave the train and walk to Slaggyford or Alston by the adjacent footpath. The Guard must be on hand to assist any passengers so wishing to leave the train.
- M4.j The Driver of the assisting locomotive(s) must carefully control the speed of the assisting locomotive(s) which must not be allowed to exceed 5 mph. The Driver must bring the assisting locomotive(s) to a stand at the protection zone of 100 yards from the disabled train and then only proceed towards the train after receiving authority to do so from the Guard (or Driver if the Guard is not available) of the disabled train.
- M4.k In the event that a failed train is not recovered complete but is removed in portions the section not removed must immediately be again protected in accordance with Rules M.1e above. The tail lamp must remain at the rear of the portion which is not to be removed. The Guard must take possession of the token or ticket which he / she must NOT surrender to the Alston Signalman. The Guard must retain the token or ticket until the whole of the train has been recovered. If this is not possible before the end of the operations day, the token or ticket must be left securely with the DOM and issued to the Guard at the start of the day when recovery of the whole of the train will be carried out.
- M4.l In the event that it is necessary to propel a passenger train, the continuous brake must be operative, and the movement must be conducted from the leading platform of the leading vehicle by the Guard, who must have access to control of the continuous brake to be able to make a direct application of the brake in the event of an emergency.
- M4.m For all trains, the Guard must be in a position to be observed at all times by the Driver in order to control the train by means of hand signals or by radio. If for any reason, communication between the Guard and the Driver of the assisting locomotive is lost, the movement must immediately come to a stop until instructed to proceed by the Guard.
- M4.n Freight trains may be propelled if no other means of recovery is possible.
- M4.o Protection in accordance with this is not required when vehicles are placed in a siding which is out of the OTW section.

#### **SECTION N – LOCOMOTIVES AND ROLLING STOCK.**

- N.a No STRPS locomotive or other traction unit of any type shall be used on the STRPS unless it is known to be in a fit state to do so. This also applies to carriages and wagons.
- N.b The STRPSPS Trustees are responsible for the certification of all locomotives and traction units that operate on the STRPS.  
This also applies to locomotives on loan to the STRPS - the owners of which must supply the STRPS with a copy of their current boiler certificate.
- N.c All STRPS locomotives will be given a thorough 'A' / FTR exam at the start of every season and a FTR (Fitness to Run) exam every steaming day thereafter.  
All 'A' & FTR exams will be fully logged and recorded.
- N.d Drivers and fireman are expected to check their locomotive as they are preparing it for duty.  
Before a locomotive leaves the shed the following tests must be carried out:
- Safety valves - lift at correct pressure.
  - Injector(s) - work correctly and pick up.
  - Gauge glass(es) - work correctly and give correct and equal readings.
  - Brakes - hand brake and steam brakes work correctly.
- N.e All tools and equipment issued for use on a locomotive must be safely stowed, e.g. fire irons, Lamps, oil bottles etc.  
Coal must not be allowed to fall off bunkers and water filler lids should be secured correctly.

- N.f If a Driver considers a locomotive to be unfit for duty, he has the right to fail it and to ask for a replacement locomotive or to wait until his locomotive has been repaired and declared fit for duty again by a qualified examining fitter.
- N.g Every STRPS locomotive has its own file containing FTR sheets, boiler certification, driver's daily logs etc.  
Drivers are expected to fill in the log each time a locomotive is used to record any defects, mileage etc.
- N.h All STRPS steam locomotives must be driven and fired with due regard for the safety of the passengers and for the train and the locomotive itself.  
Due regard should be taken of weather conditions and braking should be carried out gently.  
Line speeds should always be observed and crews should avoid excessive blowing off, black smoke and use of the whistle.
- N.i Locomotives and other traction units should only be driven by fully competent drivers with a current competency / grade card. Any driver asked to drive, or a fireman asked to fire a class or type of locomotive with which he is not familiar should seek advice and should be offered familiarisation with that locomotive before he is expected to drive it.
- N.j No steam locomotive should be left unattended when it is in steam.

**SECTION O**

**NOT USED**

**SECTION P**

**NOT USED**

**SECTION Q**

**NOT USED**

**SECTION R**

**NOT USED**

**SECTION S**

**NOT USED**

## SECTION T – POSSESSIONS AND WORK ON OR NEAR THE LINE.

The purpose of this section is to ensure the safety of trains, passengers and members of the public, and protect the personal safety of the individuals carrying out work.

### T1 Definitions and Types of Possessions on the STRPS.

- T1.a The STRPS operates two categories of possession, a Between Trains Possession and an Absolute Possession. Any work which interferes with, or might affect the integrity of, any line or the safety of trains using that line must be protected by the appropriate possession.
- T1.b Any work requiring a possession must first be agreed with the DOM and a **Person in Charge of the Possession** (PICO) must be appointed. The PICO must wear a yellow armband to identify him/her to all STRPS staff & volunteers. The PICO must wear the armband until the Possession is given up and the line cleared for normal train operation.
- T1.c Any work carried out when there is not a DOM on duty must be carried out under an Absolute Possession controlled by the PICO. If there is no Signaller on duty during the Possession, the PICO must be qualified to operate any signal box to the extent necessary.
- T1.d If there is a DOM on duty, he/she must record the Possession and which type in the DOM log book. If there is no DOM on duty, the PICO must assume responsibility for doing this.
- T1.e If all work is to be carried out more than 2 metres (6' 6ins) from any running line, there is no requirement for a Possession.

### T2 Absolute Possession.

- T2.a It is essential that all planned work which requires an Absolute Possession should be carried out on days when a passenger train service is not operating.
- T2.b The PICO must sign the TRB in Alston signal box which the Signaller, if there is one on duty, must also sign.

*"Absolute Possession Granted/Taken – '@@@@' –*

*Line Blocked –*

*<time> <signed> <countersigned>"*

NB @@@@ must identify the limits of the Possession: e.g. between Bridge 46 North of Kirkhaugh Station and Lintley station.

- T2.c In an Absolute Possession NO passenger trains are permitted, NO train other than a Works train may be permitted to enter a line or siding which is under this type of Possession. If the Possession is within the OTW section, the driver of the Works Train is permitted to pass the Section signal (A14) at danger. An Absolute Possession may be taken for part of the OTW line, which must be specified, and no trains must run over that section of the line except for works trains while the Possession is in place.
- T2.d If the Absolute Possession affects any part of the OTW section, the PICO must take Possession of the OTW Token before taking the Possession and must retain it safely until the Possession is given up. Thereupon the PICO must hand the OTW Token to the Alston Signaller. The Section signal A14 must be kept at danger for the duration of the Possession and a collar placed on the lever by the Signaller, or the PICO if no signaller is on duty. If the Absolute Possession is for work within station limits, the appropriate signals and point levers must also have a collar placed on them to protect the Possession.
- T2.e Any work involving a Works Train **MUST** be protected by an Absolute Possession.
- T2.f The Driver of a Works Train must keep a sharp lookout for the protection at sites of work and bring the train to a stand at the protection before obtaining authority from the PICO for the train to proceed past that site. When propelling, very great care must be taken when approaching the protection of any site of work.
- T2.g The Driver of a Works Train must ensure that the train is secured with as many brakes as necessary in addition to the locomotive brakes before authorising any loading or unloading of plant, materials or STRPS staff & volunteers to take place. Exception is when dropping ballast from bottom and side discharge wagons.

- T2.h The Driver of a Works Train is responsible for ensuring that all doors and loads, etc. are properly secured before the train departs from a site. The Guard, where provided will have this responsibility.
- T2.i It is the joint responsibility of the PiCoP and Signaller to ensure that all Works Train(s), complete with tail lamp, are clear of a possession before that possession is given up.
- T2.j The PiCoP must ensure, before giving up the Possession, that:-
- work is complete.
  - the line is safe to run on with/without an **Emergency Speed Restriction (ESR)** or **Temporary Speed Restriction (TSR)**, and that all plant, tools and STRPS staff & volunteers are clear of the line, before advising the DOM that the work site is safe to return to traffic use. This must be recorded in the DOM log-book.
- T2.k If it is necessary to impose a speed restriction the ES must advise the PiCoP, Signaller and the DOM. The DOM must advise train crews of any such speed restriction.
- T2.l The Signaller must then make a suitable entry in the TRB which must be countersigned by the PiCoP as follows If there is no Signaller on duty, the PiCoP must make this entry in the TRB:

*"Possession Relinquished – '@@@@' –*

*Line safe & clear to run on #-*

*<time> <signed> <countersigned>"*

# - add detail of any restriction(s) (e.g. ESR or TSR)

### **T3 Between Trains Possession.**

- T3.a A Between Trains Possession must be limited to work being carried out on days when a passenger service is operating and involves work that may be interrupted for the passage of a passenger train. A Signaller MUST be on duty for the whole duration of this type of Possession.
- T3.b When a Between Trains Possession is lifted to enable a passenger train to pass the site of the Possession, all equipment must be clear of the line and the full integrity of the line MUST BE restored.
- T3.c The need for a Between Trains Possession must be agreed with the DOM and the Possession noted in the DOM log book. Any staff or volunteers working on or near the line during between train Possessions MUST have a copy of the current service train timetable.
- T3.d The Alton Signaller and the PiCoP must agree the nature of the works and where they will be carried out. They will agree the procedure for lifting the Possession when a passenger train is to move towards the site of the Possession and for reinstating it once a passenger train has passed. Before the Possession is first taken, the Signaller and the PiCoP must both be equipped with radios and must conduct a radio check before the PiCoP leaves the signal box. The Signaller must inform the PiCoP when the first train will be despatched and the requirement for the PiCoP to give up the Possession.
- T3.e The DOM must inform Train Crews that a Between Trains Possession has been granted and the location of the works.
- T3.f The Signaller must make an entry in the TRB each time a Between Trains Possession is taken or lifted.
- T3.g The passage of passenger trains must take priority over work being carried out under a Between Trains Possession and work must cease in good time.
- T3.h A Between Trains Possession may be used for such tasks as fishplate oiling, shovel packing, sleeper changing and ballast trimming, provided only hand tools are used, a Between Trains Possession may also be used for signalling maintenance, provided the signalling equipment can be restored to normal usage when the Possession is given up, or emergency provisions (such as a Hand signaller, clamping and locking of points etc.) are put in place.
- T3.i Work which has not been planned may only be carried out on the personal authority of the DOM at the time it is wished to commence such work.

- T3.j All STRPS staff & volunteers working at the site of the work must raise one hand above the head as a signal to the Driver that they are aware of an approaching train and that they have moved to a position of safety.
- T3.k When the work is complete the ES must advise the Signaller and the Signaller must, in turn, advise the DOM. It must be clearly understood by all concerned that the Signaller has no part in protecting work carried out under a Between Trains Possession (unless the work is repair or maintenance of the signalling system – see M.3 above) and that neither fixed signals nor the OTW Token are available as protection.

#### **T4 Trolleys.**

At the STRPS there are no trolleys large enough to be marshalled in a train. The only trolley used on the railway during maintenance activities, is a small portable 4-wheel trolley, which is manually lifted on and off the track to move tools and materials at an adjacent work site. This is the type of trolley to which the following paragraphs apply.

- T4.a When not in use a trolley must either be placed on a siding or be removed from the line and placed well clear of it.
- T4.b When a hand trolley is placed on the rails in the OTW section, it must be prevented from running away by chocks being placed under the wheels.

#### **T5 Work within Sidings.**

- T5.a If the work is to be carried out in any siding, the PICoP must ensure it is protected by placing a sign "STOP restricted work area" and if required a "DO NOT MOVE" board on the vehicle(s).
- T5.b In the event that vehicles are not in a safe condition for shunting a "Do Not Move" board must be displayed on the vehicle and at the close of work an entry made in the DOM's Log Book indicating that the vehicles are unsafe to move.

### **SECTION U**

### **NOT USED**

### **SECTION V**

**SECTION W - WORKSHOPS AND RUNNING SHEDS.**

- W.a At the STRPS suitably qualified Guards & Shunters are in charge of all movements in and around running and storage sheds, workshop and yard. **See Section J for shunting procedures.** Movements must be controlled by qualified Guards & Shunters with a clear understanding between those shunting vehicles of which vehicles are to be moved and where and when movements will take place. Those present in the building who are not involved in the vehicle movement must be fully informed before vehicle movements take place.
- W.b Locomotives on shed cannot be left unattended if they are in steam.
- W.c All locomotive crews must be ready to leave the shed at their allotted time and must have with them sufficient coal and water, diesel fuel, or battery power for the work required during the day.
- W.d The safety of all people using or entering the workshop or running shed area shall be the highest priority. If the public are admitted to this area, movements must be organised in such a way that their safety is assured.  
All STRPS staff working in the area must be competent and in compliance with these rules in order

to assure the safety of themselves and others.

- W.e Locomotive crews must be vigilant on busy days when putting on injectors etc. that the overflow will not scald a member of the public. Fires should be damped down when removed from fire boxes.
- W.f All STRPS staff members are expected to return all locomotive tools to the stores at the end of the day and to generally, be aware of good housekeeping around the running and storage sheds, yard and workshop areas.
- W.g Any movements in and out of the workshop must be carried out at slow speed i.e., **2 mph** and the whistle or horn must be sounded when exiting or entering the doorways.

## **SECTION X**

**NOT USED**



## SECTION Y – COMMUNICATIONS.

- Y.a Communications have, since railways were invented, been a major factor in both causing and preventing accidents. Where an STRPS communication is of a **Safety Critical (SC)** nature the following protocols must be observed.
- Y.b Always use the best method of communication.
- Y.c Any call to a signaller or the DOM to report an emergency or an accident, must start with the words "This is an emergency call".
- Y.d In an emergency situation the radio message given should be "STOP, STOP, STOP," all trains stop.
- Y.e Train crews should use signal post telephones where they are provided at Alston Station.
- Y.f Drivers should always identify themselves by the number or identity of their locomotive and their exact location.
- Y.g All safety critical conversations should be repeated back to ensure that the message has been properly understood.
- Y.h The agreed radio Channel should always be used at the STRPS unless otherwise instructed.
- Y.i The phonetic alphabet should be used and slang and flippancy must not be used during SC conversations.
- Y.j If the call is to the Signaller, he will lead the conversation and the driver must then repeat the instructions to ensure that a clear understanding has been reached.
- Y.k The signal man, when talking with a driver who is stopped at a signal, will always conclude by saying "wait for the signal" unless he has already authorised a driver to pass a signal at danger. Even if he has already referred to clearance of the signal during the conversation, he must still conclude with these words.
- Y.l When radios are being used for shunting purposes a continual message is required – this must be at not less than 10 second intervals.
- Y.m The most important aspect of communications is to speak clearly, to identify who you are and who you are talking to, your exact location and to be clear with your message and then the repeat message. You must arrive at a clear understanding.

## SECTION Z

**NOT USED**

**APPENDIX 1**  
**DEFINITIONS & ABBREVIATIONS.**

**DEFINITIONS.**

<b>TERM</b>	<b>MEANING</b>
Brake van	A vehicle fully equipped to enable the Guard to carry out the required duties. This may be an independent vehicle or a separate compartment within another vehicle.
Competency	The recognition and qualification of STRPS staff & volunteers to be on certain parts of the Railway's premises and to undertake operational duties or other duties involving operational and personal safety on the Railway.
Continuous Automatic Air-Brake	A brake which is operated by air pressure, is coupled throughout a train, and is capable of being applied by either the Driver or Guard or automatically should the air pipe be opened to atmosphere for any reason.
Continuous Automatic Locomotive-Brake	A system fitted to some locomotives which causes automatic application of the locomotive brake when a loss of pressure in the train pipe is detected.
Disconnection of signalling equipment	The disconnection from its normal means of operation (e.g. lever, switch or electrical circuit) of any point, signal, locking frame, release, or other electrical circuit which forms part of the signalling system or any part of the interlocking.
Duty Operations Manager	Appointed to be in charge of, and responsible for, the operation of the Railway on all occasions when passenger trains are operating.
Emergency Speed restriction	A speed restriction which has not been formally advised by notice or signing. Advice is verbal
Engineering Supervisor	Person in charge of technical aspects of works (particularly to the infrastructure)
Infrastructure engineering work	Any work carried out on any part of the infrastructure of the Railway or its property.
Line	Abbreviated term for 'on or near the line'
Lineside	The remaining space between the area defined as 'on or near the line' and the Railway's nearest boundary fence.
loading or unloading	The loading or unloading of permanent way materials, rolling stock components (other than minor handheld items), plant or similar equipment, and large tools or items that require handling by more than a single person.
On or near the line	That area which is between the running rails and also the area within 6ft. 6inches (2 metres) of the nearest rail edge.
One Train Working	A system where only one train or locomotive (or more than one coupled together) is allowed to occupy a single line section at any one time.
Protection	A method of physically indicating the position of a failed train or other obstruction (such as a portion of a divided Works Train).
Running Line	A main line on which scheduled services (mostly passenger trains) are operated
Running Movement	A train movement wholly along a Running Line and not classed as Shunting
Section Signal	The signal permitting access to an OTW Section
Shunter	Person in charge of Shunting.

Shunting	The movement of rail vehicles other than in a train movement. This includes such as moving them from one line or siding to another for loading purposes or, to form them into a train or for the purpose of working on them.
Signal	Signals are used to control movements and can be either fixed signals (which are static), or hand signals, (which are given by STRPS staff & volunteers either by movement of the arms or using a flag, or lamp or whistle).
Train Operations	The running of trains on the Railway and the instructions and Rules directly relating to train operations.

<b>ABBREVIATION</b>	<b>FULL TERM</b>
ALC	Accommodation Level Crossing
CP	Competent Person
COSHH	Control of Substances Harmful to Health
C&W	Carriage and Wagon
DOM	Duty Operations Manager
DSD	Drivers Safety Device
ECS	Empty Coaching Stock
ESR	Emergency Speed restriction
FTR	Fitness to Run
FPL	Facing Point Lock
HMRI	Her Majesty's Railway Inspectorate
HSE	Health and Safety Executive
HVC	High Visibility Clothing
ICP	Independent Competent Person
LE	Light Engine
LOLER	Lifting Operations and Lifting Equipment Regulations 1998
ORR	Office of Rail and Road
OTW	One Train Working by Staff
PiCoP	Person in Charge of the Possession
PICoW	Person in Charge of the Work
PPE	Personal Protective Equipment
PSI	Pounds per Square Inch
RAIB	Rail Accident Investigation Branch
RIDDOR	Reporting if Injuries, Diseases and Dangerous Occurrences Regulations 1995
ROGS	Railways and other Guided Systems
POS	Position of Safety
PSR	Permanent Speed restriction
PTS	Personal Track Safety
PW	Permanent Way
SC	Safety Critical
SMS	Safety Management System
S&T	Signal & Telegraph
<b>ABBREVIATION</b>	<b>FULL TERM</b>

STR	South Tynedale Railway (the name used by STRPSPS to market the railway's services)
STRPS	South Tynedale Railway Preservation Society Ltd (the governing body of the South Tynedale Railway)
TRB	Train Register Book
TSR	Temporary Speed Restrictions

**APPENDIX TWO.  
DEFINITIONS AND DUTIES.**

1. The Duty Operations Manager (DOM).
2. Drivers – steam, diesel or battery electric.
3. Firemen - diesel and battery electric second men.
4. Shunters.
5. Guards.
6. Signalman.
7. Platform staff.

### **1. Duty Operations Manager.**

The Duty Operations Manager (DOM) oversees all operations and movements on the STRPS and has to deal with any incidents which might arise.

A suitably qualified DOM must be appointed and on duty at Alston station on all occasions when any rail movements are being made on the railway.

During the time that he is on duty the DOM is the "Responsible Person" in charge of the railway's operations and the management and monitoring of operational and staff standards.

The DOM has the authority to suspend from duty any member of staff who is seen to be unfit for duty or who fails to comply with the requirements of this rule book or any supplementary or special instructions etc.

The DOM is responsible, on signing on for duty, for ensuring that all operational staff roster requirements for that day have been met and, if this is not the case, for attempting to arrange suitable cover for any uncovered duties.

### **2. Train Crew, Signalmen, Shunters and Platform Staff.**

Steam or Diesel drivers receive their instructions from the Guard and are required to operate all STRPS trains safely and as required.

Firemen and second men work for and are responsible to the driver. They must keep a good look out when not otherwise occupied and assist the driver by observing fixed signals.

Guards are responsible for the safe working of their train. They should give clear instructions to the driver and they receive instructions from the platform staff when preparing to despatch a train.

Signalmen control all train movements by the use of fixed signals and they also collect in and hand out the tokens to train crews entering sections.

The station platform staff when on duty, control the safe use of the station, the safe loading of passengers on to trains and their safe exit from arriving trains. They also assist with the safe despatch of trains from the station.



**SOUTH TYNEDALE RAILWAY  
RULE BOOK  
APPENDIX 3  
SOUTH TYNEDALE  
RAILWAY  
LINE DIAGRAM**

**March 2016 EDITION**

MILEAGE		Mile Posts	DESCRIPTION	Bridge No.	Level Crossing No.	LINE DIAGRAM	REMARKS
Miles	Chains						
		0	Buffers				
		0.56	Shunting Signal				
		0.65	Points				
		0.86	Platform D.P.				
		2.73	ALSTON				
		2.81	Booking Office				
		4.23	Down Signal				
		4.60	Platform				
		4.85	Level Crossing "Alston Station"		STR-1		
		5.59	Points				
		5.61	Signal Box 'ALSTON'				
		5.67	Up Signal				
		6.71	Speed Limit				
		8.51	Down Signal				
		9.01	Points				
		9.32	Commencement of River Wall				
		10.70	Up Signal Start/End OTW				
		14.14	Termination of River Wall				
		17.95	Culvert "Shield Well"	60			
		20.00					Ground Frame 5 Levers "Carriage Sidings"
		23.46	Speed Limit				
		24.27	Down Whistle Board				
		26.75	Occupation Level Crossing "Water Authority"		STR-2		
		28.62	Up/Down Whistle Board				
		31.48	Overhead Electric Wires "Holms" Footpath Crossing		STR-3		Ground Frame 2 Levers "Holms"
		31.74	Accommodation Bridge	59			
		33.41	Up Distant Signal				
		34.32	Speed Limit				
		34.63	Up Whistle Board				
		36.47	Accommodation Bridge	58			
		40.00					

42.74		Commencement of Viaduct over River South Tyne				
43.95		"Tyne Viaduct"	57			
45.16		Termination of Viaduct				
60.00	¾					
70.80		Accommodation Bridge	56			
78.97		Culvert "Wanwood Well"	55			
1 0.00	1					
1.42		Accommodation Bridge	54			
5.45		Small Culvert	53a			
14.26		Culvert	53			
15.31		Down Whistle Board				
19.52		Accommodation Crossing "Wanwood"	STR-4			
20.00	¼					
23.73		Up Whistle Board				
35.72		Accommodation Bridge	52			
		Platform				
		GILDERDALE (Closed)				
		Platform				
40.00	½					

43.87		Commencement of Viaduct over Gilderdale Burn					
45.01		Cumberland County Boundary Northumberland	51				
46.15		Termination of Viaduct					
58.09		Accommodation Bridge	50				
60.00	¾						
60.17		Culvert	49				
72.65		Down Whistle Board					
76.86		Accommodation Crossing "Lort Bum"	STR-5				
77.95		Down Distant Signal					
2	0.00	2					
0.32		Up Whistle Board					
1.34		Commencement of Viaduct over Lort Bum					
2.39		"Whitley Viaduct"	48				
3.44		Termination of Viaduct					
4.59		Culvert	47				
		Overhead Electric Wires Down Stop Board Start/End OTW					Provision only for 2 Section working
16.48		Speed Limit					
16.91		Water Tower					
18.30		Points					
18.76		Kirkhaugh South G F					
20.00	¼						
20.05		Up Stop Board					Provision only for 2 Section working

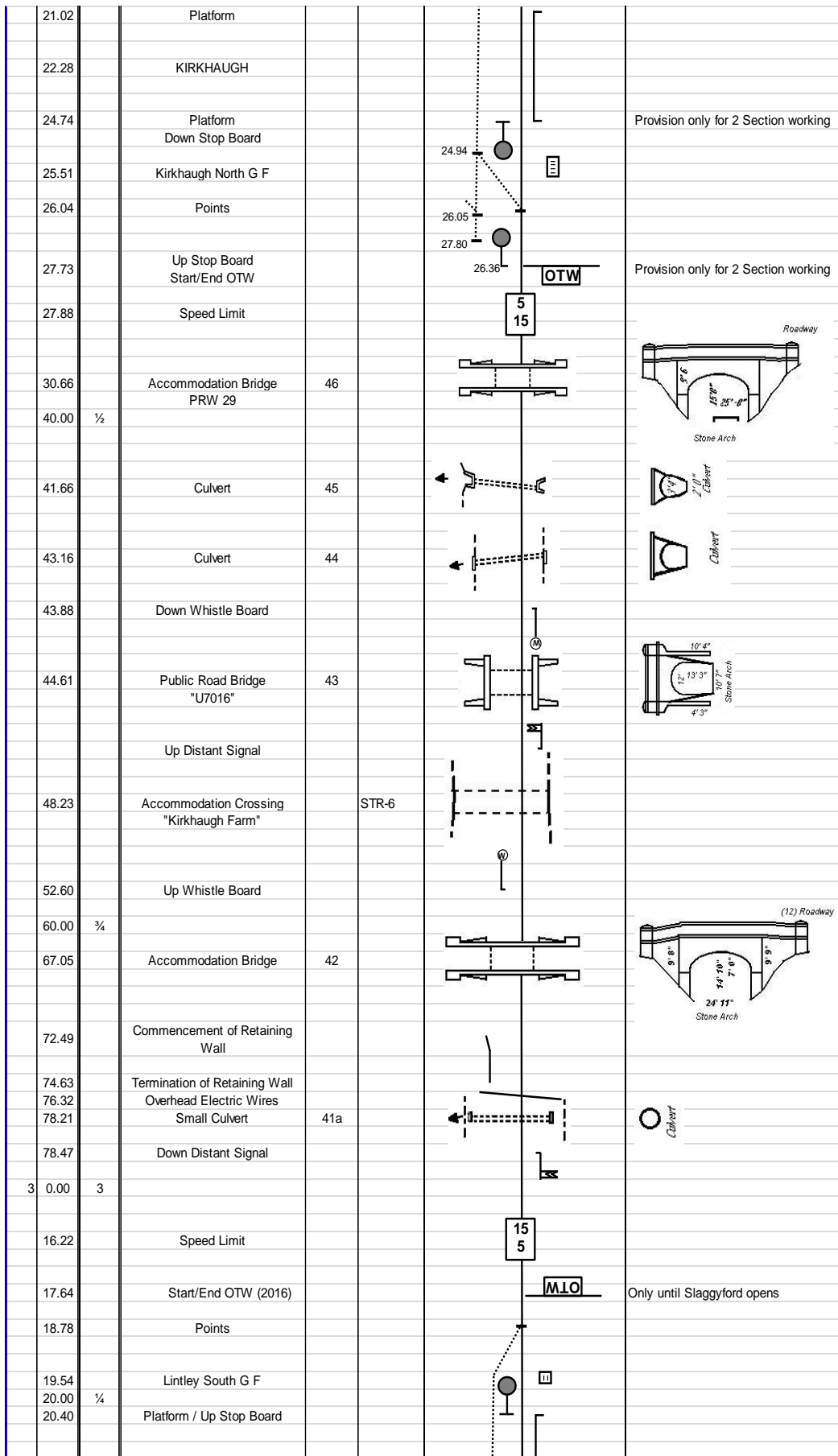

22.41		LINTLEY HALT				
24.43		Platform / Down Stop Board				
25.25		Shelter				
25.55		Footpath Crossing	STR-6A			
26.88		Points				
27.48		Up Stop Board				
		Speed Limit				
29.67		Up Whistle Board				
34.01		Occupation Bridge	41			
35.87		Commencement of Viaduct over Thornhope Burn				
37.08		"Lintley Viaduct"	40			<i>Stone Viaduct width between Piers 21' 4"</i>
38.29		Termination of Viaduct				
40.00	1/2	End of Line (2016)				
40.03		Overhead Electric Wires				
39.50		Down Whistle Board				
43.71		Accommodation Crossing "Thornhope"	STR-7			
47.92		Up Whistle Board				
50.53		Public Road Bridge "A689 Thornhope Rail"	39			
60.00	3/4					
64.04		Culvert "Crookeld Well"	38			
73.59		Accommodation Bridge	37			
		Down Distant Signal				
78.35		Culvert "Thompson's Well"	36			
4	0.00	4				

